

TERMS AND CONDITIONS

FOR

PROCESSING

OF GAS

AT

NYHAMNA GAS PLANT

Valid from 1 October 2022

TABLE OF CONTENTS

1	APPLICABILITY, RELATIONSHIP, DEFINITIONS, AND DOCUMENTS	4
1.1	Applicability	4
1.2	Relationship	4
1.3	Definitions	4
1.4	Appendices	10
1.5	Hierarchy	10
2	TRANSPORTATION COMMITMENT AND OPERATION	11
2.1	Shipper’s obligation to provide Linefill	11
2.2	Transportation Commitment	11
2.3	Daily Transportation Commitment	11
2.4	Operation	11
2.5	Planned maintenance	11
2.6	Safety, system integrity and/or environmental protection	12
2.7	Installations, connections, modifications, tie-in	12
2.8	Priorities	12
3	DELIVERY RIGHT AND OBLIGATION AND OFFTAKE	13
3.1	Delivery Right and Obligation	13
3.2	Forecasts	13
3.3	Nomination	13
3.4	Offtake	13
3.5	Changes to Booked Capacity	13
4	OPERATING AND QUALITY REQUIREMENTS	13
4.1	Requirements at the Entry Point(s)	13
4.2	Right to refuse delivery	14
4.3	Gas not complying with requirements at the Entry Point	14
4.4	Right to take operational actions	14
4.5	Quality Blending Service	14
4.6	Requirements at the Exit Point(s)	14
4.7	Right to refuse redelivery	14
5	TARIFF	15
5.1	Transportation Tariffs	15
5.2	Capacity Fee Obligation	15
5.3	Other costs	15
5.4	Removal and abandonment costs	15
6	MONTHLY INVOICE AND PAYMENT	16
6.1	Monthly statement and invoice	16
6.2	Payment	16
6.3	Adjustment of preliminary invoice	17
6.4	Interest on amount due	17
6.5	Suspension and termination	17
6.6	Changes in Shipper’s credit rating	17
6.7	Change in financial circumstances	18
6.8	Audit	18
6.9	Rounding	19

7	MEASUREMENT, TEST AND ANALYSES	19
7.1	General.....	19
7.2	Measurement audit.....	19
8	DETERMINATION OF QUANTITIES.....	19
8.1	Allocation of Gas	19
8.2	Fuel Gas and Replacement Gas.....	19
9	GUARANTEE.....	20
9.1	Shipper's guarantee.....	20
9.2	Nyhamna Joint Venture's guarantee	20
10	LIABILITY AND INSURANCE.....	20
10.1	Risk of loss of Gas	20
10.2	Shipper's indemnification right.....	20
10.3	Nyhamna Joint Venture's and the Operator's indemnification right.....	21
10.4	Use of Third Party facilities	21
10.5	Liability for Off-spec Gas	22
10.6	Escape of Gas	22
10.7	Insurance	23
10.8	Nyhamna Joint Venture's liability	23
10.9	Shippers' shared liability.....	23
11	FORCE MAJEURE.....	24
11.1	Force Majeure	24
11.2	Relief due to Force Majeure	24
11.3	Notification and Remedies	24
11.4	Long term Force Majeure.....	25
12	MISCELLANEOUS	25
12.1	Notices	25
12.2	Notice in case of restructuring	25
12.3	Confidentiality.....	25
12.4	Telecommunications and data transmission.....	27
12.5	Time reference	27
12.6	Sanctions.....	27
12.7	Amendments to the Terms and Conditions including the Appendices.....	27
13	TERM OF AGREEMENT	27
13.1	Termination of the Processing Agreement.....	27
13.2	Survival of Termination	28
14	ASSIGNMENT	28
15	APPLICABLE LAW AND ARBITRATION	28

1 APPLICABILITY, RELATIONSHIP, DEFINITIONS, AND DOCUMENTS

1.1 Applicability

The objective of these Terms and Conditions is to regulate the rights and obligations of the Parties with regard to the provision and use of the Processing Services.

The Terms and Conditions apply to all of the Shipper's Bookings in the Transportation System and any Processing Services provided in respect of Shipper's Gas.

The Shipper's Bookings and the Terms and Conditions, the Appendices and the relevant parts of the Shipper Manual constitute the Processing Agreement.

The Parties' rights and obligations pursuant to these Terms and Conditions shall be interpreted and construed to comply with, and be limited by, applicable statutory laws and regulations pertaining to the Transportation System, hereunder "*Forskrift 27. juni 1997 nr. 653 til lov om petroleumsvirksomhet kapittel 9*" and *Tarifforskriften* as amended from time to time.

1.2 Relationship

The Processing Agreement is entered into between the Shipper and Nyhamna Joint Venture.

The Operator is Nyhamna Joint Venture's representative under the Processing Agreement. The Operator will conduct all operations in the Transportation System and, on behalf of Nyhamna Joint Venture, provide the Processing Services and execute all Nyhamna Joint Venture's rights and obligations under the Processing Agreement.

1.3 Definitions

In the Terms and Conditions and in the Appendices the following terms shall have the meaning ascribed to them below:

1. "Affiliated Company" shall in relation to a Participant or the Shipper, mean:
 - (i) any enterprise which directly or indirectly holds more than 50 per cent of the share capital or the votes, or in any other way directly or indirectly exercises a controlling interest, in such Participant or Shipper, or
 - (ii) any enterprise in which such Participant or Shipper directly or indirectly holds more than 50 per cent of the

share capital or the votes, or in any other way directly or indirectly exercises a controlling interest, or

- (iii) any enterprise of which more than 50 per cent of share capital or votes are held directly or indirectly, or which in any other way directly or indirectly is controlled, by one or more enterprise(s) which hold directly or indirectly more than 50 percent of the share capital or the votes, or in any other way exercises directly or indirectly a controlling interest, in such Participant or Shipper.
2. "Agent" shall mean any person who has been appointed by the Shipper and who acts on behalf of the Shipper with regard to that Shipper's rights and obligations in connection with the Processing Agreement.
 3. "Appendix" or "Appendices" shall mean the documents listed in Article 1.4.
 4. "Article" shall mean an article of the Terms and Conditions.
 5. "Bilateral Transaction" shall mean transactions related to change of entitlement to Gas upstream of or at any Entry Point and/or at any Exit Point, which will affect deliveries or redeliveries of Shipper's Gas.
 6. "Booked Capacity" shall mean the Booked Processing Capacity, Booked Quality Blending Service and / or Interruptible Booking, as the case may be, according to the Shipper's Bookings.
 7. "Booked Processing Capacity" shall mean the Shipper's Processing Capacity rights for the services in the Transportation System.
 8. "Booked Quality Blending Service" shall mean the Shipper's rights for blending services.
 9. "Booking" shall mean a Transportation Request made by the Shipper and accepted by the Operator in accordance with the Booking Manual.
 10. "Booking Manual" shall mean the detailed procedures established by the Operator, at any time applicable, for inter alia the reservation, allocation, transfer, release and adjustment of capacity in the Transportation System.
 11. "Booking Period" shall mean the period that consists of each of the Days for which the Shipper has Booked Capacity.
 12. "Business Day" shall mean any calendar day that is neither a Saturday, a Sunday nor public holiday in Norway.

13. "Capacity Fee Obligation" shall have the meaning set forth in Article 5.2 first paragraph.
14. "Company Agreement" shall mean the "Company Agreement for Utilisation of Gassco Systems" between the Operator and the Shipper.
15. "Condensate" shall mean the components of the Rich Gas with molecular structure consisting of two or more carbon atoms condensed to the liquid state.
16. "Condensate Lifting Procedure" shall mean the detailed regulation for lifting of Condensate as described in Appendix C.
17. "Confidential Information" shall mean any information obtained by the Shipper from the Operator or by the Operator from the Shipper in connection with the Processing Agreement, which is not available in the public domain.
18. "Contractor" shall mean any person who has entered into an agreement with a Party for the supply of materials and/or services in connection with the Processing Agreement and who acts in its own name and on its own behalf.
19. "Cumulative Reserved Capacity" shall mean the Booked Capacity less capacity initially reserved as Interruptible Booking at the relevant booking point. If Daily Nominations for any period are higher than Booked Capacity, the highest quantity shall be included in "Cumulative Reserved Capacity".
20. "Daily Nominations" shall have the meaning set forth in Article 3.3 first paragraph.
21. "Daily Transportation Commitment" shall have the meaning set forth in Article 2.3.
22. "Day" shall mean the period beginning at 06:00 hours on a day and ending at 06:00 hours on the following day. The date of any Day shall be the date of its beginning as herein defined.
23. "Degree Celsius" or "°C" shall be determined as the particular interval between any temperature in Kelvin minus the temperature of 273.15 Kelvin.
24. "Desk Quotation" shall mean the broker proposal obtained by the Operator each year for insurance of the Transportation System, including Third Party liability insurance.
25. "Dry Gas" shall mean Gas which has been processed to remove all or some of the Condensate and the water vapour in order to meet the Specifications for delivery at the Exit Point.

26. "Entry Point" shall mean the point at which the Shipper will deliver Gas to Nyhamna Joint Venture for Processing Services. The Entry Points are further defined in the Transportation System Description.
27. "Exit Point" shall mean the point at which Nyhamna Joint Venture will redeliver Gas to the Shipper. The Exit Points are further defined in the Transportation System Description.
28. "Financially Qualified Company" shall mean an undertaking that has passed and continues to pass the credit rating conditions given in the Qualification of Shipper Procedure.
29. "Force Majeure" shall have the meaning set forth in Article 11.1.
30. "Fuel Gas" shall mean Gas used as fuel for the operation of the Transportation System.
31. "Gas" shall mean any Dry Gas, Rich Gas and/or Condensate, as the case may be.
32. "Gassco Booking System" shall mean the internet based solution for inter alia booking of capacity and services in the Transportation System.
33. "Interruptible Booking" shall mean a Transportation Request in respect of Interruptible Capacity made by the Shipper and accepted by the Operator in accordance with the Booking Manual.
34. "Interruptible Capacity" shall mean capacity that may be interrupted by the Operator at any time in order to fulfil shippers' nominations under a firm capacity reservation.
35. "Landfall Bund" shall mean the dry stone revetment that covers the trench where the 30" Ormen Lange production pipelines, Polarled pipeline and the Langed pipeline comes onshore.
36. "Linefill" shall have the meaning set forth in Article 2.1.
37. "Maintenance Period" shall have the meaning set forth in Article 2.5.
38. "Ministry" shall mean the Norwegian Ministry of Petroleum and Energy or its successor.
39. "Month" shall mean the period beginning on the first Day of any calendar month and ending on the first Day of the succeeding calendar month.
40. "Nyhamna Joint Venture" shall mean the joint venture owning the Transportation System.

41. "Off-spec Gas" shall mean Gas that does not meet the Specifications at the relevant Entry Point(s) and / or Exit Point.
42. "Operations Manual" shall mean the detailed requirements for operation of the Transportation System as described in Appendix A.
43. "Operator" shall mean Gassco AS or its successor as determined by the Ministry.
44. "Origo Shipment Planning" shall mean the internet based solution for inter alia nomination of Condensate out of the Transportation System as further described in Appendix C.
45. "Participant" shall mean any of the owners of Nyhamna Joint Venture at any time.
46. "Party" shall mean either Nyhamna Joint Venture or the Shipper, and "Parties" shall mean Nyhamna Joint Venture and the Shipper.
47. "Processing Agreement" shall have the meaning set forth in Article 1.1 third paragraph.
48. "Processing Capacity" shall mean the services in Nyhamna Joint Venture for processing of Gas. The Processing Capacity is further defined in the Transportation System Description.
49. "Processing Services" shall mean all or part of the services offered to the Shipper by Nyhamna Joint Venture in the Transportation System.
50. "Qualification of Shipper Procedure" shall mean the at any time applicable part of the Booking Manual regarding the credit rating requirements applicable for undertakings that want to transport Gas in the Transportation System.
51. "Quality Blending Service" shall mean the services in the Transportation System for blending of Off-spec Gas. The Quality Blending Service is further defined in the Transportation System Description.
52. "Reasonable and Prudent" when used to describe the standard of care to be exercised by a Party or the Operator in performing its obligations hereunder shall mean that degree of diligence, prudence and foresight reasonably and ordinarily exercised by experienced companies engaged in the same line of business under the same or similar circumstances and conditions having due consideration to the interests of the other Party.
53. "Replacement Gas" shall mean Gas for replacement of minor losses under normal operation of the Transportation System.

54. "Rich Gas" shall mean any hydrocarbon or mixture of hydrocarbons and non-combustible gases in the gaseous state, which is extracted from the reservoirs in a particular field in its natural state or together with the liquid hydrocarbons, processed and exported in dense phase in order to meet the Specification for delivery into the Transportation System.
55. "Shipper" shall mean the company designated as such in the Booking and thereby being a Party to the Processing Agreement. When the term "shipper" or "shippers" is used it shall mean the parties designated as such in some or all bookings in the Transportation System and thereby parties to some or all processing agreements with Nyhamna Joint Venture. The term shipper/ shippers shall also include the Shipper.
56. "Shipper Manual" shall mean detailed procedure established by the Operator, at any time applicable, for inter alia regulating the communication between the Shipper and the Operator.
57. "Shipper's Bookings" shall mean the sum of the Bookings the Shipper holds at any time.
58. "Shipper's Facilities" shall mean;
- a) any platforms, pipelines, wells, plant, machinery or any other equipment or facilities (whether or not owned or operated by the Shipper) upstream of the Entry Point(s) used from time to time to produce, receive, process, compress, store, treat and transport Gas to be delivered at the Entry Point(s) under the Processing Agreement; and/or
 - b) any pipelines, plant, machinery, meters, valves or other equipment or facilities (whether or not owned or operated by the Shipper) at or immediately downstream of the Exit Point(s) required for the Shipper to take redelivery of Gas at the Exit Point(s).
59. "Sm³" (standard cubic metre) of Gas shall mean the quantity of Gas at 15 Degrees Celsius and at an absolute pressure of 1.01325 bar and when free of water vapour occupies the volume of 1 cubic metre.
60. "Specifications" shall mean the operating conditions and quality specifications given in the Operations Manual articles 4.1 and 4.2.
61. "Subcontractor" shall mean any person who has entered into an agreement with a Contractor for the supply of materials and/or services in connection with the Terms and Conditions and who acts in its own name and on its own behalf.
62. "Tariff(s)" shall mean the at any time applicable fees payable for the Processing Services.

63. "Tarifforskriften" shall mean "Forskrift om fastsettelse av tariffer m.v. for bestemte innretninger av 20. desember 2002" as amended from time to time.
64. "Terms and Conditions" shall mean the rules herein setting out the Parties rights and obligations regarding the services in the Transportation System.
65. "Third Party" shall mean any party other than the Operator and the Parties.
66. "Transportation Commitment" shall have the meaning set forth in Article 2.2.
67. "Transportation Request" shall mean a request for Processing Services submitted to the Operator in accordance with the Booking Manual.
68. "Transportation System" shall mean the facilities at any time in place to receive Shipper's Gas at the Entry Point(s), process, handle, transport and redeliver the Gas at the Exit Point(s), in accordance with the Processing Agreement, as detailed in Transportation System Description. The Transportation System is determined as Area P in Tarifforskriften.
69. "Transportation System Description" shall mean the detailed description of the Transportation System described in Appendix B.
70. "Year" shall mean a period of 12 Months commencing at 06:00 hours on the 1 October of any calendar year and ending at 06:00 hours on the 1 October in the succeeding calendar year, and the Year shall be named after the year in which the Year commence.

1.4 Appendices

The following Appendices are attached to the Terms and Conditions:

Appendix A:	Operations Manual
Appendix B:	Transportation System Description
Appendix C:	Condensate Lifting Procedure
Appendix D:	Principles for Operator's publication of operational information

1.5 Hierarchy

Unless otherwise explicitly stated or clearly appears from the context, in the event of any conflict between the provisions in the various parts of the Processing Agreement, they shall be given priority in the following order:

- 1) The Terms and Conditions
- 2) The Appendices
- 3) The Shipper Manual

2 TRANSPORTATION COMMITMENT AND OPERATION

2.1 Shipper's obligation to provide Linefill

In order for Nyhamna Joint Venture to take on the Transportation Commitment, the Shipper is obliged to provide Nyhamna Joint Venture with its share of the minimum quantity of Gas necessary to pressurise the Transportation System ("Linefill").

The basis for and any change or recalculation of the ownership of the Linefill shall be in accordance with the procedure set forth in the Shipper Manual.

2.2 Transportation Commitment

Nyhamna Joint Venture undertakes to receive quantities of Gas at the Entry Point(s), process Gas up to the Booked Processing Capacity and redeliver Gas to the Shipper at each Exit Point(s) throughout the Booking Period (the "Transportation Commitment").

Nyhamna Joint Venture does not undertake any Transportation Commitment in respect of Booked Quality Blending Service and / or Interruptible Capacity.

2.3 Daily Transportation Commitment

Nyhamna Joint Venture's Daily Transportation Commitment shall unless otherwise specified in the Processing Agreement be equal to the quantities nominated by the Shipper in accordance with Article 3.3.

If the Shipper after the deadline for the Daily Nominations makes a re-nomination, the Operator shall use reasonable endeavours to accept the re-nomination. If the Operator accepts the re-nomination, the Transportation Commitment shall be equal to the re-nominated quantities.

2.4 Operation

Throughout the Booking Period Nyhamna Joint Venture shall operate, maintain and repair the Transportation System in a Reasonable and Prudent manner.

2.5 Planned maintenance

Nyhamna Joint Venture shall each Year for reasons of planned maintenance of the Transportation System have the right to reduce (if necessary down to 0) the Processing Services (the "Maintenance Period").

The Maintenance Period shall be within the Months of April through September. The Maintenance Period shall be determined by the Operator in accordance with the Operations Manual article 2.7. The Operator shall

coordinate the Maintenance Period in order to minimise the disruption to the Processing Services and, subject to the Operator's final decision, to coincide with the maintenance period for relevant interfacing systems.

The Maintenance Period shall be unlimited, provided, however, that the Operator shall use all reasonable efforts to minimise the duration of the Maintenance Period.

2.6 Safety, system integrity and/or environmental protection

Nyhamna Joint Venture may for reasons of safety, system integrity and/or environmental protection curtail or shut-off the Shipper's delivery of Gas to the Transportation System to perform repairs and/or extraordinary maintenance of the Transportation System, provided that said actions cannot reasonably be deferred to a subsequent Maintenance Period.

The curtailment or shut-off period will be determined by the Operator acting in a Reasonable and Prudent manner. The Operator shall promptly notify the Shipper of the reason for such action, the extent of curtailment or shut-off and the possible duration of such curtailment or shut-off. To the extent time is available, the Operator shall coordinate the curtailment or shut-off with the Shipper in order to minimise the effect of such curtailment or shut-off.

2.7 Installations, connections, modifications, tie-in

Nyhamna Joint Venture may curtail or shut-off the Shipper's delivery of Gas to the Transportation System if necessary for reasons of any operations, inter alia installations, connections, modifications, tie-in operations, disconnections and removals which cannot be reasonably deferred to a Maintenance Period.

Nyhamna Joint Venture's right to curtail or shut-off the Shipper's delivery of Gas shall be unlimited, provided, however, that the Operator shall use all reasonable efforts to minimise the duration of any such curtailment or shut-off.

The Operator shall as soon as possible and not less than 120 days prior to commencement notify the Shipper of the timing and extent of any such operations. In the planning and scheduling of the operations the Operator shall seek to minimise necessary shut-off periods and to cause least possible disruptions to the Processing Services including minimising the negative effects for the Shipper.

2.8 Priorities

In case of reduced capacity in the Transportation System the Operator will reallocate capacity to the shippers according to the priority rules set out in the Operations Manual article 3.3.

3 DELIVERY RIGHT AND OBLIGATION AND OFFTAKE

3.1 Delivery Right and Obligation

The Shipper has, throughout the Booking Period, the right and obligation to deliver at the Entry Point(s), the quantities of Gas corresponding to its Daily Nominations.

3.2 Forecasts

The Shipper shall provide forecasts of its deliveries of Gas at each Entry Point. The content of the forecasts shall be in accordance with the requirements of the Operations Manual article 2.1.

3.3 Nomination

The Shipper shall for each Day make nominations of quantities of Gas to be delivered at each of the Entry Point(s) and redelivered at each of the Exit Point(s) (the "Daily Nominations"). The Daily Nominations shall be made, and adjusted in case of re-nominations, in accordance with the Operations Manual article 2.3.

The Daily Nominations shall not exceed the Shipper's Booked Capacity for the Day in question.

Notwithstanding the above, the nominations for redelivery of Condensate at the relevant Exit Point shall be made in accordance with the Condensate Lifting Procedures.

3.4 Offtake

The Shipper shall on each Day be obliged to accept redelivery at the Exit Point(s) quantities of Gas equal to the Daily Nominations.

The Shipper's rights and obligations to take Condensate shall be as set out in the Condensate Lifting Procedure.

3.5 Changes to Booked Capacity

Any changes to the Shipper's Booked Capacity shall be made in accordance with the Booking Manual.

4 OPERATING AND QUALITY REQUIREMENTS

4.1 Requirements at the Entry Point(s)

The Shipper shall at the Entry Point(s) deliver Gas that meets the Specifications.

Notwithstanding the above, if the Shipper's Gas is delivered together with other shippers' Gas at the Entry Point, the Shipper's Gas shall be deemed to meet the Specifications if the commingled stream of all

shippers' Gas delivered at the Entry Point, meets the Specifications at such Entry Point. This shall only apply for Off-spec Gas where there are no Quality Services.

4.2 Right to refuse delivery

The Operator may at all times refuse to accept the Shipper's Off-spec Gas or the Shipper's Gas if delivered in an Off-spec Gas commingled stream. The Shipper shall in such case immediately stop any delivery of Gas.

4.3 Gas not complying with requirements at the Entry Point

Notwithstanding Articles 4.1 and 4.2, Nyhamna Joint Venture shall use reasonable endeavour to accept Off-spec Gas or the Shipper's Gas if delivered in an Off-spec Gas commingled stream, provided that, in the reasonable opinion of the Operator, such Off-spec Gas would neither be detrimental to the operation of the Transportation System nor affect Nyhamna Joint Venture's ability to redeliver Gas to all shippers in accordance with Article 4.6. The above shall only apply for Off-spec Gas where there are no Quality Blending Services.

4.4 Right to take operational actions

If the Shipper has delivered Off-spec Gas or has delivered Gas in an Off-spec Gas commingled stream, the Operator shall have the right to take necessary operational actions to dispose of the Shipper's Gas at a convenient location or, if possible and subject to the respective field operator's prior approval, backflow the Gas.

4.5 Quality Blending Service

If Shipper has delivered Off-spec Gas under a Booked Quality Blending Service the Gas shall be considered to be Off-spec Gas at the Entry Point and the liability associated with Off-spec Gas deliveries shall remain with the Shipper.

Quality Blending Service is pending on other Gas being delivered into the Transportation System and will only be offered if, in the Operators reasonable opinion, Gas can be redelivered within the Specifications at the Exit Points.

4.6 Requirements at the Exit Point(s)

Nyhamna Joint Venture shall redeliver at the Exit Point(s) Gas that meets the Specifications.

4.7 Right to refuse redelivery

The Shipper may refuse to accept redelivery of its Gas provided that the transportation system downstream of the Exit Point, based on the quality provisions of that system, refuses to take said Gas. In such case the Operator shall in agreement with the Shipper and at the Shipper's cost take the necessary operational action to dispose of such Gas.

However, if Article 4.6 is not fulfilled by Nyhamna Joint Venture, then the Operator shall, notwithstanding Articles 10.2 and 10.3, at Nyhamna Joint Venture's cost take the necessary operational action to dispose of such Gas.

5 TARIFF

5.1 Transportation Tariffs

The Tariffs for the Processing Services shall be calculated in accordance with Tarifforskriften.

The Tariffs shall be published on www.gassco.no.

5.2 Capacity Fee Obligation

Throughout the Booking Period, the Shipper is obliged to pay the Tariffs for a quantity of Gas corresponding to the Booked Processing Capacity and/or the Booked Quality Blending Service (the "Capacity Fee Obligation"), or the Daily Nominations, whichever is the higher.

The Capacity Fee Obligation shall be suspended during any period and to the extent Nyhamna Joint Venture does not provide Processing Services including, but not limited to;

- a) events described in Articles 2.5, 2.6 or 2.7 or Force Majeure (according to Article 11) affecting the Transportation System preventing the Shipper's Gas from being received, processed, handled or redelivered by Nyhamna Joint Venture,
- b) periods when Nyhamna Joint Venture does not redeliver Gas in accordance with Article 4.6 and the Shipper has the right according to Article 4.7 second paragraph to refuse to take redelivery,

5.3 Other costs

The Shipper shall reimburse the Operator or Nyhamna Joint Venture, as applicable, relevant taxes and/or fees levied on the Shipper's Gas that the Operator or Nyhamna Joint Venture pays on behalf of the Shipper.

5.4 Removal and abandonment costs

Costs for removal and/or abandonment according to legal requirement, of all or any part of the Transportation System, and any costs including but not limited to clean up costs associated therewith, shall be paid by the Shipper.

Costs for removal and/or abandonment shall first be allocated between the period before 1 October 2017 and after 1 October 2017 in proportion

to cumulative throughput in the period before 1 October 2017 and Cumulative Reserved Capacity in the period after 1 October 2017.

Total cumulative throughput in the period prior to 1 October 2017 is 186.761 MSm³.

The Shipper's share of removal and abandonment costs in the period after 1 October 2017 is the Shipper's Cumulative Reserved Capacity for Processing Capacity in proportion to all shippers' Cumulative Reserved Capacity for Processing Capacity. If substantial parts of the Nyhamna Gas Plant is removed prior to full removal, the Cumulative Reserved Capacity in the period the removed parts of the Nyhamna Gas Plant were in operation shall be used.

6 MONTHLY INVOICE AND PAYMENT

6.1 Monthly statement and invoice

On or before the 7th Business Day of each Month or later subject to postponed allocation report according to the Operations Manual article 6.1.1, the Operator shall submit an invoice to the Shipper showing the total amount payable by the Shipper to Nyhamna Joint Venture for the preceding Month. The invoice shall inter alia specify;

- a) the Booked Capacity,
- b) the Tariffs applicable,
- c) deductions, if any, in Capacity Fee Obligation according to Article 5.2 second paragraph, and
- d) any other information that influence the amount payable.

The Tariffs and the total amount payable shall be in the official Norwegian currency.

If all data is not available, Nyhamna Joint Venture may issue a preliminary invoice.

6.2 Payment

The amount payable by the Shipper shall be paid and credited to bank accounts designated by Nyhamna Joint Venture on the 20th day of the Month in which the invoice referred to in Article 6.1 was submitted or not later than 10 days after receipt of said invoice, whichever date comes later.

The invoiced amount shall except in the case of manifest errors be paid without any deductions whether or not any part of or the entire amount is disputed.

6.3 Adjustment of preliminary invoice

If any invoice was based on preliminary figures Nyhamna Joint Venture shall, as soon as possible, render to the Shipper a new invoice showing the appropriate adjustments to the preliminary invoice in the same manner as described in Article 6.1. The amount resulting from the adjustment, including interest, shall if payable by the Shipper, be paid not later than 20 days after the date of receipt of said new invoice. The amount resulting from the adjustment, including interest, shall if payable by Nyhamna Joint Venture, be paid not later than 20 days after the date of submission of said new invoice.

Interest on the amount of adjustment shall be calculated at an annual rate equal to 3 months Norwegian Interbank Offered Rate (NIBOR) as published by the Dagens Næringsliv, Oslo, on the first Business Day in the Month of issuance of the new invoice.

Interest shall be paid for the period starting from and including the due date of the relevant preliminary invoice and ending on but excluding the value date of payment of said adjustment.

6.4 Interest on amount due

Should any Party fail to make any payment due hereunder at the time and in the manner provided for herein, the amount due shall bear interest for the period starting on and including the due date for payment and ending on, but excluding the value date for payment, calculated in accordance with the Law relating to Interest on Overdue Payments etc., of 17 December 1976 no. 100 ("Forsinkelsesrenteloven").

6.5 Suspension and termination

If the Shipper's failure to pay any sum due continues for 5 Business Days or more following the due date for payment of such amount, then at any time thereafter Nyhamna Joint Venture may by 5 Business Days' notice to the Shipper, suspend the Processing Services until the amount due has been paid by the Shipper (or by a guarantor on behalf of the Shipper).

The suspension shall not relieve the Shipper from the Capacity Fee Obligation.

If the Shipper's default continues for 60 days or more following the due date for payment, then at any time thereafter Nyhamna Joint Venture may by notice to the Shipper, terminate the Processing Agreement from the date specified in such notice.

6.6 Changes in Shipper's credit rating

If during the Booking Period the Shipper's credit rating falls below the credit rating level at any time required in the Qualification of Shipper Procedure or Article 6.7 is applicable and the Shipper does not provide a

guarantee as specified in the Qualification of Shipper Procedure, then the Shipper shall be obliged to make its Tariff payments in advance.

The Shipper shall be required to pre-pay an amount equal to the estimated sum of the Tariffs applicable to the Shipper's Booked Capacity for the current and the following 2 Months, and then by pre-payment on the 20th day of each Month maintain a pre-paid amount equal to the estimated sum of the Tariffs applicable to the Shipper's Booked Capacity for the current and the following 2 Months.

If the Shipper fails to make any required pre-payment, Nyhamna Joint Venture shall have the right to suspend the Processing Services or terminate the Processing Agreement immediately and Articles 6.4 and 6.5 second paragraph shall apply.

6.7 Change in financial circumstances

If at any time within the Booking Period

- a) the Shipper initiates a merger, dissolution, liquidation, winding up, reduction of share capital or a similar process, or
- b) there is a material deterioration in the financial resources of the Shipper,

that is likely to have an adverse effect on the Shipper's ability to fulfil its obligations under the Processing Agreement, the Operator may require the Shipper to provide a guarantee as specified in the Qualification of Shipper Procedure.

The Shipper shall notify the Operator immediately of circumstances described above and/or in case of a credit rating downgrade as described in the Booking Manual article 3.1.

6.8 Audit

The Shipper shall, upon 30 days' notice to the Operator, have the right to examine and audit the Operator's books and records for the years in which the Shipper's Gas was transported in the Transportation System and which are relevant to the allocation of Shipper's Gas and the Tariffs charged to the Shipper.

The audits shall be conducted within the 24 months period following the end of the year in question. If the audit reveals any inaccuracy in any invoice rendered, the necessary adjustments to such invoice and payments including interest in accordance with Article 6.3, shall be made promptly. No adjustment for any invoice or payments shall be made with respect to any claims filed after the expiration of the 24 months.

The Shipper shall conduct the audits at reasonable hours and in a manner, which will result in a minimum of inconvenience to Nyhamna

Joint Venture and the Operator. The Shipper shall cover its own expenses for the audit.

The Shipper's right to audit shall not include Confidential Information regarding other shippers. If examination of such Confidential Information is necessary, an independent auditor shall perform such part of the audit. The independent auditor shall only confirm whether the Operator's calculations are correct and shall not reveal any Confidential Information to the Shipper.

Subject to the preceding paragraph, the Shipper shall endeavour to conduct the audit during the same period as other shippers.

6.9 Rounding

All calculations in the Processing Agreement shall be made to 7 places of decimals. A figure of 5 or more in the 8th decimal place shall cause a rounding up of the 7th decimal place.

7 MEASUREMENT, TEST AND ANALYSES

7.1 General

All measurement, testing, on-line analysis and sampling shall be performed in accordance with the requirements in the Operations Manual article 5.

7.2 Measurement audit

The Parties may conduct such audits as provided for in the Operations Manual article 5 at each other's facilities. Such audits shall be performed during the normal office hours in effect at the facilities at the time of the audit and in a manner which shall result in a minimum of inconvenience.

8 DETERMINATION OF QUANTITIES

8.1 Allocation of Gas

The allocation to the Shipper of quantities of Gas hereunder shall be determined in accordance with the Operations Manual article 6.

8.2 Fuel Gas and Replacement Gas

Fuel Gas and Replacement Gas shall be supplied by the Shipper in kind based on the Shipper's Daily Nomination.

Deliveries of Fuel Gas and Replacement Gas shall be made in accordance with the Operations Manual article 6.

9 GUARANTEE

9.1 Shipper's guarantee

The Shipper guarantees that it at the time of delivery and continuing up and until the time of redelivery has the right to dispose of all Gas delivered by it to Nyhamna Joint Venture.

The Shipper agrees to indemnify Nyhamna Joint Venture and the Operator against all suits, judgements, actions, debts, accounts, damages, costs, losses and expenses arising from or out of any legal claims of any and all persons to or against the Gas. Nyhamna Joint Venture shall, within a reasonable time after receiving notice of the assertion of any such claim, notify the Shipper of such fact and shall permit them to participate in the defence against such claim.

9.2 Nyhamna Joint Venture's guarantee

Nyhamna Joint Venture guarantees that the Gas redelivered to the Shipper at the Exit Point(s) shall be free from all claims of any kind and nature, except in case any such claims existed at the time of receipt by Nyhamna Joint Venture.

Nyhamna Joint Venture agrees to indemnify the Shipper against all suits, judgements, actions, debts, accounts, damages, costs, losses and expenses arising from or out of any legal claims of any and all persons to or against said Gas except to the extent such claim or defects are attributable to the Gas which the Shipper delivered or caused to be delivered to Nyhamna Joint Venture hereunder and existed at the time of such delivery. The Shipper shall, within a reasonable time after receiving notice of the assertion of any claim, notify Nyhamna Joint Venture of such fact and shall permit it to participate in the defence against such claim.

10 LIABILITY AND INSURANCE

10.1 Risk of loss of Gas

Risk of loss of and damage to the Shipper's Gas shall at all times be and remain with the Shipper.

For the purpose of determining any risk or liability under the Processing Agreement, the Gas delivered shall be deemed to be situated in the Transportation System in accordance with the Booked Processing Capacity.

10.2 Shipper's indemnification right

Nyhamna Joint Venture shall indemnify and hold the Shipper and/or its Agents, and/or its Contractors and/or Subcontractors and any of the aforesaid's employees, harmless from and against any loss, damage and/or expense arising out of any claim for;

- a) injuries to or death of any employees of the Participants and/or the Operator, and/or their Contractors and/or Subcontractors, and/or
- b) loss of or damage to the property of Nyhamna Joint Venture and/or the Operator, and/or their Contractors and/or Subcontractors, and any of the aforesaid's employees, and/or
- c) all indirect losses, which include but are not limited to loss of profit, to Nyhamna Joint Venture and/or the Operator, and/or their Contractors and/or Subcontractors and any of the aforesaid's employees,

arising out of or in connection with the Processing Agreement, including the non-performance by the Shipper of any of its obligations, except where such claim is a result of gross negligence or wilful misconduct by the managerial and/or supervisory personnel of the Shipper and/or its Agents, its Contractors and/or Subcontractors.

10.3 Nyhamna Joint Venture's and the Operator's indemnification right

The Shipper shall indemnify and hold Nyhamna Joint Venture and the Operator, and/or their Contractors and/or Subcontractors and any of the aforesaid's employees, harmless from and against any loss, damage and/or expense arising out of any claim for;

- a) injuries to or death of any employees of the Shipper and/or its Agents, its Contractors and/or Subcontractors, and/or
- b) loss of or damage to the property of the Shipper and/or its Agents, its Contractors and/or Subcontractors, and any of the aforesaid's employees, and/or
- c) all indirect losses, which include but are not limited to loss of profit, to the Shipper and/or its Agents, its Contractors and/or Subcontractors, and any of the aforesaid's employees,

arising out of or in connection with the Processing Agreement, including the non-performance by Nyhamna Joint Venture or the Operator of any of its obligations, except where such claim is a result of gross negligence or wilful misconduct by the managerial and/or supervisory personnel of the Participants or the Operator and/or their Contractors and/or Subcontractors.

10.4 Use of Third Party facilities

To the extent that Nyhamna Joint Venture makes use of Third Party facilities for the Processing Services, these Terms and Conditions shall apply to such use.

10.5 Liability for Off-spec Gas

Notwithstanding Article 10.2, the Shipper having delivered Off-spec Gas shall be liable for any loss of Gas and/or direct costs to Nyhamna Joint Venture caused by or resulting from the deliveries of Off-spec Gas. If the Shipper's Gas is delivered in an Off-spec Gas commingled stream, the Shipper shall be liable pro rata to its share in the Off-spec Gas commingled stream, unless;

- a) the Operator in a joint statement from all shippers delivering Gas in the commingled stream has been instructed to distribute such liability otherwise, or
- b) the Shipper, or a group of shippers, stipulates another distribution of liability within 10 Business Days after the Operator have informed about the intention to distribute the liability pro rata to the share in the Off-spec Gas commingled stream, and none of the other shippers concerned have objection to this within 10 Business Days following notice of such other distribution.

The Operator shall endeavour to minimise such costs and losses.

10.6 Escape of Gas

Notwithstanding Articles 10.2 and 10.3, but subject to the second and third paragraph of this Article 10.6, all expenses and damages which may be incurred by either of the Parties as a result of environmental pollution, explosion, fire or any other events arising out of the escape of Gas from the Transportation System shall be divided between all shippers of Gas in the Transportation System as determined in accordance with Article 10.9.

Notwithstanding Article 10.2 and the first paragraph of this Article 10.6, if such pollution, explosion, fire or other events are caused by an act or omission by the Shipper, then the Shipper shall be held liable, provided, however, that each shipper, including the Shipper, shall indemnify and hold Nyhamna Joint Venture and the Operator harmless from and against expenses and damages incurred as a result thereof as determined in accordance with Article 10.9. The Shipper hereby accepts and agrees to indemnify Nyhamna Joint Venture and the Operator in such manner.

However, if such expenses and damages are caused by gross negligence or wilful misconduct by the managerial and/or supervisory personnel of Nyhamna Joint Venture and/or the Operator, their Contractors and/or Subcontractors, then Nyhamna Joint Venture shall indemnify the Shipper.

Irrespective of the liability principles stated above, all expenses and damages which may be incurred as a result of environmental pollution, explosion, fire or any other events arising out of the escape of Gas from the Transportation System shall be recovered under the insurances

arranged by Nyhamna Joint Venture pursuant to Article 10.7 up to the maximum limits of such insurances as stipulated in the Desk Quotation.

To the extent such expenses and damages can be recovered under the insurances arranged by Nyhamna Joint Venture pursuant to Article 10.7, such recovered amounts shall be credited the shippers pro rata to each shipper's liability in respect of such expenses and damages as determined in accordance with Article 10.9.

If the total loss exceeds the maximum limits as stipulated in the Desk Quotation, then the shippers will be responsible for the excess amount as calculated in accordance with Article 10.9.

10.7 Insurance

Nyhamna Joint Venture shall be responsible for arranging all insurance in respect of the Transportation System, as well as Third Party liability insurance covering liabilities arising out of or in connection with any activity or omission related to the Processing Agreement.

All such insurance shall contain waivers of all rights of subrogation in favour of the Shipper (including its Affiliated Companies) and/or its Agents, its Contractors and/or Subcontractors, and any of the aforesaid's employees. Further, such insurance shall specify that the shippers' liabilities under Article 10.6 shall be covered under the insurance up to the respective maximum limit as stipulated in the Desk Quotation.

The Shipper shall be responsible for arranging all insurance in respect of the property of the Shipper.

All Shipper's insurances shall contain waivers of all rights of subrogation in favour of Nyhamna Joint Venture, the Participants (including their Affiliated Companies) and the Operator, and/or their Contractors and/or Subcontractors, and any of the aforesaid's employees.

Nyhamna Joint Venture and the Shipper shall upon request submit to the Operator their insurance programmes relevant to the Processing Agreement and undertake to inform the Operator of changes made therein.

10.8 Nyhamna Joint Venture's liability

The liability of each Participant related to the Processing Agreement shall be several, according to its ownership interest in Nyhamna Joint Venture at any time, and not joint or collective.

10.9 Shippers' shared liability

The liability for expenses and damages for which neither an individual shipper nor Nyhamna Joint Venture can be held liable according to the Processing Agreement and, subject to Article 10.6 third paragraph, the

liability for expenses and damages which may be incurred by either of the Parties as a result of environmental pollution, explosion, fire or any other events arising out of the escape of Gas from the Transportation System as described in Article 10.6, shall be shared between the shippers. The Shipper's liability shall be determined according to its share of the total Booked Processing Capacity in the Transportation System for the 365 Days preceding the Day when the event causing expenses, losses and/or damages occurred.

11 FORCE MAJEURE

11.1 Force Majeure

Force Majeure shall mean any event beyond Nyhamna Joint Venture's and the Operator's control related to the Transportation System and the operation thereof or any event beyond the Shipper's control related to the Shipper's Facilities and the operation thereof that the Operator or the Shipper, as the case may be, could not reasonably be expected to have taken into account at the time when the relevant Booking(s) was made.

11.2 Relief due to Force Majeure

As long as and to the extent a Party is rendered unable to perform any of its obligations due to Force Majeure, the Party shall be relieved from liability for failure to perform such obligations other than the obligation of payment of money.

A Party rendered unable wholly or in part to make any payment due and payable, shall not be relieved from its obligation to pay interest, according to the interest rate given in Article 6.3, for the period from the due date of payment until payment is actually made.

11.3 Notification and Remedies

A Party claiming relief on account of Force Majeure shall;

- a) as soon as practical give notice to the other Party of the event said to constitute Force Majeure, such notice including information about the circumstances and a statement of the steps and time believed necessary to remedy the Force Majeure situation and afford reasonable facilities for a site inspection if desired at the expense and risk of the Party making examination, and
- b) proceed with diligence and at its own expense to take steps to remedy the failure as soon as possible in a Reasonable and Prudent manner, provided always that no Party shall be required to make more than commercially reasonable investments nor shall it be obligated to settle any labour dispute except in such manner as it shall in its own judgement think fit.

11.4 Long term Force Majeure

If a Party due to an event of Force Majeure has been rendered unable to perform any of its obligations for a period of 24 consecutive Months, either Party shall have the right, after the expiry of such period, to terminate the part of the Processing Agreement affected by Force Majeure.

12 MISCELLANEOUS

12.1 Notices

Any notice or other communication required or permitted to be given pursuant to the Processing Agreement shall be in writing and may be given by delivering the same by hand or by sending the same by prepaid first class post or electronic mail to the relevant address, or electronic mail address set out in the Company Agreement or such other address or electronic mail address as any Party may give in writing, from time to time, to the other in accordance with this Article 12.1.

Any such notice, given as aforesaid, shall be deemed to have been given or received at the time of delivery if delivered by hand, at the time at which confirmation of successful delivery is received if sent by electronic mail and on the 5th Business Day next following the day of sending if sent by prepaid first class post. The use of electronic mail for transfer of documents shall at all times be in accordance with internationally recognised standards as may be adopted by the Operator. The chosen standard shall enable the use of digital signatures or similar electronic safety device, encryption, filing and retrieving.

12.2 Notice in case of restructuring

If the Shipper initiate a merger, dissolution, liquidation, winding up, reduction of share capital or a similar process that is likely to have an adverse effect on the Shipper's ability to fulfil its obligations under the Processing Agreement, or suffers a material credit rating downgrade also after the Shipper's last Booking Period has expired, the Shipper shall give notice to the Operator immediately after such process have been initiated and / or such credit rating downgrade has occurred.

12.3 Confidentiality

Confidential Information shall not be disclosed by the Shipper or the Operator to any Third Party, or by the Operator to any of the Participants. However, the Confidential Information may be disclosed by;

- a) the Operator to;
 - (i) the Agent or Affiliated Company of the Shipper,

- (ii) the Contractors and/or Subcontractors of the Operator to the extent disclosure is required for the proper execution of their work,
- (iii) the advisers of the Operator or to arbitrators to the extent it is required for the proper execution of their assignments, or
- (iv) governmental authorities in connection with required reports.

b) the Shipper to;

- (i) the Agent or any Affiliated Company of the Shipper,
- (ii) any bona fide potential buyer of the Shipper's Gas or an interest in the sources delivering Gas under the Processing Agreement,
- (iii) any bona fide potential assignee of the Shipper's Processing Agreement,
- (iv) any relevant institution in connection with the borrowing of funds or issuance or sale of security,
- (v) the stock exchanges on which any securities of the Shipper are or may be quoted to the extent required by the applicable rules of such stock exchanges,
- (vi) the advisers of the Shipper or to arbitrators to the extent it is required for the proper execution of their assignments, or
- (vii) any governmental authorities in connection with required reports.

Notwithstanding the above, the Operator may;

- a) provide to the relevant field operator historical lifting data in order to maintain the gas lifting account,
- b) provide Confidential Information that has both been made anonymous and aggregated with other shippers' confidential information,
- c) at any time in connection with bona fide legal disputes arising out of the Processing Agreement, provide the Participants with any relevant Confidential Information,
- d) make Confidential Information pertaining to planned and unplanned outages publicly available in accordance with the principles for publication as laid down in Appendix D hereto.

Where disclosure of Confidential Information is made to a Third Party or Participant, the disclosing Party shall ensure that appropriate safeguards are undertaken to prevent the Third Party or the Participant, as the case may be, from making any further disclosure of such information.

12.4 Telecommunications and data transmission

The Shipper shall, at its own cost and expense, install or ensure that necessary telecommunication equipment according to the Operator's specifications is installed.

12.5 Time reference

Any reference to time shall be to the time in force in Norway.

12.6 Sanctions

Shipper shall ensure that vessels used for lifting Condensate are not in breach of or violates any applicable UN, US, UK, EU and/or Norwegian sanctions in force at any given time until the vessel has left the jetty, and to notify the Operator immediately if such breach or violation may occur.

Shipper shall indemnify and hold Nyhamna Joint Venture and the Operator, and/or their Contractors and/or Subcontractors and/or any of the aforesaid's employees harmless from and against any loss, damage and/or expense arising out of any breach or violation of any of the above mentioned sanctions.

12.7 Amendments to the Terms and Conditions including the Appendices

Amendments to the Terms and Conditions including the Appendices are subject to approval by the Ministry. Proposals for such amendments shall be developed by the Operator. Before any such proposals are submitted to the Ministry the Operator shall submit the proposals in writing for consultation in accordance with "*Forskrift 27. juni 1997 nr. 653 til lov om petroleumsvirksomhet*", section 65, second paragraph.

The Shipper shall submit its comments within 20 Business Days after receipt of such notice from the Operator. The Operator shall take due consideration of the Shipper's comments and submit them to the Ministry, along with the proposals.

The amendments shall enter into force as determined by the Ministry.

13 TERM OF AGREEMENT

13.1 Termination of the Processing Agreement

The Processing Agreement shall terminate on the earlier of;

- a) the date when the Shipper's last Booking Period has expired,
- b) the date Nyhamna Joint Venture ceases to own and operate the Transportation System provided Nyhamna Joint Venture has given 24 months prior notice of said event,

- c) the date when the licence period(s) for the Transportation System expires, or
- d) the date specified in the termination notice issued according to Article 6.5 or on date of termination according to Article 6.6 or Article 11.4.

13.2 Survival of Termination

The termination shall be without prejudice to any payment obligation being unfulfilled or any liability incurred and not paid at the date of termination.

The Parties rights and obligations according to Articles 6.8 and 12.3 shall remain for a period of 3 years from the date of termination.

The Shipper's obligation according to Articles 5.4 and 12.2 shall survive the termination of the Processing Agreement.

14 ASSIGNMENT

The Shipper may only assign its rights and obligations under the Processing Agreement subject to prior written consent from Nyhamna Joint Venture.

Notwithstanding the above, the Shipper may assign its rights and obligations to unused Booked Capacity provided that;

- a) the Operator has confirmed that the assignee;
 - (i) is a Financially Qualified Company,
 - (ii) has entered into a Company Agreement, and
 - (iii) fulfils the requirements in the Booking Manual for obtaining Booked Capacity in the secondary market,

and,

- b) the assignee has accepted to be bound by the Processing Agreement.

15 APPLICABLE LAW AND ARBITRATION

The Processing Agreement shall be governed and construed in accordance with Norwegian law.

Any controversy or dispute that may arise in connection with or as a result of the Processing Agreement and which cannot be resolved by mutual agreement between the Parties shall be finally decided by arbitration in Stavanger in accordance with Norwegian Arbitration Act of 14 May 2004 No 25 ("Lov om voldgift"), as subsequently amended or

replaced. Unless otherwise agreed, the arbitration proceedings, documents and correspondence in connection with the arbitration and awards delivered pursuant to this Article 15 are confidential in accordance with the confidentiality provisions herein.

Documents and statements in the Norwegian and English language shall be allowed in any procedure involving arbitration. Translation thereof shall be at the expense of the Party requesting such translation.

APPENDIX A

TO

TERMS AND CONDITIONS FOR

PROCESSING OF GAS AT

NYHAMNA GAS PLANT

OPERATIONS MANUAL

TABLE OF CONTENTS

1	APPLICABILITY, DEFINITIONS, PRIORITIES AND AMENDMENTS.....	4
1.1	Applicability.....	4
1.2	Definitions	4
1.3	Relation to the Shipper Manual.....	5
2	NOMINATIONS	5
2.1	Forecasts	5
2.2	Availability	6
2.3	Daily Nominations and re-nominations	6
2.4	Shipper’s Gas Delivery Requirement	7
2.5	Reporting	7
2.6	Planned Maintenance	7
2.7	Meetings.....	8
2.8	Coordination	8
3	OPERATIONS.....	8
3.1	Obligations prior to commencement of Processing Services	8
3.2	Capacity tests	8
3.3	Transportation Curtailment.....	9
3.4	Interruption	9
3.5	Minimum throughput.....	9
3.6	Maximum increase in throughput	9
4	OPERATING CONDITIONS AND QUALITY REQUIREMENTS	10
4.1	Requirements at the Entry Point(s).....	10
4.2	Requirements at the Exit Point(s).....	10
4.3	Combination of Gas in order to meet the quality requirements.....	10
4.4	Blending Service	10
4.5	Condensate product quality compensation.....	11
5	MEASUREMENTS, TESTS AND ANALYSES.....	11
5.1	General.....	11
5.2	Measurements, tests and analyses at the Entry Point(s).....	11
5.3	Measurements, tests and analyses at the Exit Point(s).....	11
5.4	Facilities upstream of the Entry Point(s).....	11
5.5	Facilities downstream of the Entry Point(s)	12
5.6	Design of measurement facilities	12
5.7	Maintenance and calibration	13
5.8	Analysis	14
5.9	Codes and standards.....	15
6	ALLOCATION OF SHIPPER’S GAS.....	17
6.1	General.....	17
6.2	Gas allocation.....	18
7	TABLES	21
7.1	Entry specifications for Gas entering Area P at Entry Point P1.....	21

7.2 Entry specifications for Gas entering Area P at Entry Point P2..... 22

7.3 Exit specifications for Gas being redelivered at Exit Point P1 23

7.4 Exit specifications for Gas being redelivered at Exit Point P2 (Gas Power Plant) 24

7.5 Exit specifications for Condensate being redelivered at Exit Point P3..... 25

1 APPLICABILITY, DEFINITIONS, PRIORITIES AND AMENDMENTS

1.1 Applicability

This Operations Manual sets out the operational regulation regarding the Shipper's and Nyhamna Joint Venture's rights and obligations given in the Terms and Conditions.

The Operator will execute Nyhamna Joint Venture's rights and obligations according to this Operations Manual.

1.2 Definitions

The definitions set out in the Terms and Conditions applies to this Operations Manual. In addition, the following terms shall have the meaning ascribed to them below:

1. "Accounting Period" shall mean a Month.
2. "Components" means nitrogen, carbon dioxide, methane, ethane, propane, iso-butane, normal butane, iso-pentanes, normal pentane, hexane, heptane, octanes, nonanes, decanes and heavier hydrocarbons.
3. "Entry Point Availability" shall mean the quantity of Gas that at a given point in time can be delivered from a Field at an Entry Point.
4. "Exit Point Availability" shall for any Exit Point mean the quantity of Dry Gas that Nyhamna Joint Venture at a given time is able to redeliver to all shippers at that Exit Point.
5. "Field" shall mean any production facility producing Gas for deliveries to Nyhamna Joint Venture for Processing Services.
6. "Gas Delivery Requirement" shall mean the actual quantities of Gas to be delivered from the Shipper's Field in order to meet the Shipper's nominations. The Shipper's Gas Delivery Requirement shall be calculated according to article 2.4.
7. "Gross Calorific Value" or "GCV" shall mean the superior gross calorific value as defined in ISO 6976. The combustion reference temperature shall be 25 °C.
8. "Kilowatt-hour" or "kWh" shall mean 3.6 MJ.
9. "MegaJoule" or "MJ" shall mean 1,000,000 joules which shall be identical with the definition of the derived "SI unit of quantity of heat J" as defined in ISO 80000 Quantities and units.
10. "Nm³" (normal cubic metre) of Gas shall mean the quantity of Gas which at 0 Degrees Celsius and at an absolute pressure of 1.01325 bar and when free of water vapour occupies the volume of 1 cubic metre.

11. "Processing Capacity Availability" shall mean the quantity of Gas that Nyhamna Joint Venture at a given time is able to process for all shippers.
12. "Quality Blending Service Availability" shall for any Quality Blending Service mean the quantity of Gas that Nyhamna Joint Venture at a given time is able to handle for all shippers in such Quality Blending Service.
13. "Shipper's Field Operator" shall mean the operator of the Shipper's Field(s).
14. "Shipper's Field" shall mean the production facilities producing Shipper's Gas for deliveries, either directly to or through transportation and/or processing facilities upstream of the Entry Point for the Shipper's Gas, to the Transportation System, whether the production facilities are owned by the Shipper or not.
15. "Transportation Curtailment" shall mean any event affecting the Transportation System, including, but not limited to, events described in the Terms and Conditions Articles 2.5, 2.6, 2.7, or Force Majeure, that reduces the capacity in the Transportation System.
16. "Wobbe Index" or "WI" shall mean the GCV divided by the square root of the relative density.

1.3 Relation to the Shipper Manual

The regulations set out in the Operations Manual are supplemented by the Shipper Manual. In case of conflict between the Operations Manual and the Shipper Manual, the regulation in the Operations Manual shall unless otherwise expressly stated, always prevail.

2 NOMINATIONS

2.1 Forecasts

Forecast according to this article 2.1 shall have content and be in accordance with time limits as described in the Shipper Manual.

The Shipper shall issue, or provide Shipper's Field Operator to issue, to the Operator:

- Long-term forecasts
- Monthly forecasts (15-month rolling)
- Weekly forecasts

of its deliveries of Gas at each Entry Point.

The forecasts shall in all aspects be consistent with the relevant forecasts submitted to the Norwegian authorities.

The Operator shall submit to the Shipper forecasts for the Condensate to be redelivered at the relevant Exit Point(s).

The Shipper shall ensure that the Shipper's Field Operator(s) informs the Operator of relevant plans for maintenance, tests, shut-down, temporary periods of decreased/increased deliveries of Gas, minimum export requirement and available processing capacity at the Shipper's Field(s), and the time and duration for such events, as soon as such information is available.

The Operator shall inform the Shipper of programmes for planned maintenance, shut-downs, tests and any other activities related to the Transportation System and Fields which could affect the Entry Point Availability, Processing Capacity Availability, Quality Blending Service Availability and/or the Exit Point Availability or otherwise influence delivery and/or redelivery of Shipper's Gas.

2.2 Availability

The Operator shall inform the Shipper daily of its available quantities of Gas at Shipper's Field(s).

The Shipper shall ensure that the Shipper's Field Operator daily informs the Operator of the available quantities of Gas at the Shipper's Field(s).

2.3 Daily Nominations and re-nominations

The Shipper shall submit to the Operator its Daily Nominations, except for Interruptible Capacity, for each Day before 14:00 hours on the preceding Day.

The Shipper shall submit to the Operator its Daily Nominations for Interruptible Capacity in accordance with the procedure described in the Shipper Manual.

The Daily Nominations shall specify deliveries and redeliveries in energy units and shall have a content as further described in the Shipper Manual.

The Operator shall accept the Shipper's Daily Nomination submitted within the deadline in the first paragraph. If the Shipper after the deadline makes a re-nomination, the Operator shall use reasonable endeavours to accept the re-nomination. If the Operator accepts the re-nomination, the re-nomination shall be deemed to be a Daily Nomination.

The Operator has a right to instruct the Shipper to re-nominate if;

- the Daily Nomination deviates significantly from the Shipper's weekly forecast, or
- the Daily Nomination deviates significantly from the Daily Nomination for the previous Day.

Unless otherwise agreed with the Operator, the Shipper shall not be entitled to nominate deliveries or redeliveries of Gas as an uneven flow-rate throughout the Day.

The nomination procedure is further described in the Shipper Manual.

2.4 Shipper's Gas Delivery Requirement

The Gas Delivery Requirement shall be the Gas Delivery Requirement at the Gassled Area D entry point D9 (Nyhamna) multiplied with the Nyhamna Gas Plant rich gas factor for the respective Field(s).

The Nyhamna Gas Plant rich gas factor is the Shipper's Field delivery at the Entry Point divided by the Shipper's Field allocated Dry Gas at the Exit Point(s).

2.5 Reporting

The Operator shall on a daily basis notify the Shipper of the Shipper's Gas delivered at the Entry Point(s) and redelivered at the Exit Point(s) (except for the Condensate) on the previous Day, and the status of the Shipper's operational accounts.

The Shipper shall ensure that the Shipper's Field Operator(s) on a daily basis notifies the Operator of the quantity of Gas delivered at the relevant Entry Point(s) on the previous Day.

The Shipper shall ensure that the Shipper's Field Operator(s) on a monthly basis notifies the Operator of the quantity of Gas delivered by the Shipper at the relevant Entry Point(s) each Day of the previous Month.

The Shipper shall notify the Operator of the date and time of any Bilateral Transactions as soon as reasonably practical. Any Bilateral Transactions that takes place within Day shall for the purpose of these Terms and Conditions take effect as from the time the appurtenant re-nomination takes effect.

2.6 Planned Maintenance

The Operator shall each calendar year during the period between May and December discuss with the Shipper the maintenance plan for the following two calendar years. The decision on the duration of and the reduction in Processing Services during the Maintenance Period(s) shall be made solely by the Operator. However, when deciding upon the Maintenance Period(s) the Operator shall inter alia take into account;

- a. that the Maintenance Period(s) shall be determined with the objective to minimise disruption to the Processing Services to the extent possible,
- b. the need for maintenance of the Fields,
- c. the need for maintenance of the Transportation System, any downstream receiving terminal(s) and/or other adjacent transportation systems,
- d. the need for maintenance of facilities used for onshore transportation of Gas.

The Operator shall before 16 December in each calendar year submit a notice to the Shipper stating the Maintenance Period(s), any possible quality implications and the transportation capacity available to the Shipper on each Day of the Maintenance Period(s) for the following two calendar years.

2.7 Meetings

The Operator and the Shipper shall, if requested, meet in order to discuss subjects related to the delivery and redelivery of Gas under the Transportation Agreement.

The schedules for meeting and for exchanging information may be adjusted to coincide with the Shipper's procedure(s) for reporting to the Norwegian authorities.

Furthermore, the Operator and the Shipper shall meet when requested by the Shipper.

2.8 Coordination

The Operator and the Shipper shall coordinate their activities regarding necessary Gas quantities to be delivered to the Transportation System to meet the Shipper's requirements for redelivery of Gas pursuant to article 2. The Shipper shall ensure that the relevant Shipper's Field Operator(s) participate in such coordination activities.

3 OPERATIONS

3.1 Obligations prior to commencement of Processing Services

Prior to the commencement of the Processing Services:

- a. The Shipper shall at the Operator's request provide evidence to the Operator that telemetry and communication facilities for monitoring of the operating conditions and the quality of Gas to be delivered at the Entry Point are in good operational order;
- b. The Shipper shall make available to the Operator the necessary analysis and test results to verify that the Gas to be delivered at the Entry Point is within the Specifications as set forth in article 4.1. The requirements according to this article 3.1 shall also upon the Operator's request apply after any major shut-off;
- c. The Operator shall at the Shipper's request provide evidence to the Shipper that telemetry and communication facilities for monitoring of the operating conditions and the quality of Gas at the Exit Point(s) are in good operational order;
- d. The Operator shall at the Shipper's request, allow for connection of the downstream transportation system operator's telemetry systems to the Transportation System for exchange of relevant telemetry signals.

3.2 Capacity tests

The Operator shall be entitled to perform capacity tests in the Transportation System. If such tests would require changes or stable conditions in Gas delivery

and/or redelivery, the Shipper shall in cooperation with the Shipper's Field Operators use reasonable endeavours to comply with requests for such changes.

3.3 Transportation Curtailment

In the event of Transportation Curtailment, the Operator shall calculate the new Entry Point Availability, Processing Capacity Availability, Quality Blending Service Availability and / or Exit Point Availability, for the Shipper and inform the Shipper without delay.

The Shipper's new reduced Entry Point Availability, Processing Capacity Availability, Quality Blending Service Availability and / or Exit Point Availability shall be calculated as the Shipper's pro rata share of all shippers' Bookings for the relevant service for the Day for which the total capacity is reduced.

In case of Transportation Curtailment after the Day has started the already delivered, processed and / or redelivered quantities of Gas shall be allocated to the Shipper in accordance with its Daily Nominations, for the period prior to the point in time when the Transportation Curtailment occurred.

3.4 Interruption

In case of interruption of Interruptible Capacity, the Operator shall calculate the Shipper's new reduced capacity for the relevant service as its pro rata share of all shippers' Interruptible Booking at the relevant service for the Day for which the Interruptible Capacity is reduced.

In case of interruption after the Day has started the already delivered, processed and / or redelivered quantities of Gas shall be allocated to the Shipper for the period prior to the point in time when the interruption occurred.

3.5 Minimum throughput

If on any Day the sum of quantities of Gas nominated by all shippers does not add up to the minimum throughput capacity required to operate the Transportation System, Nyhamna Joint Venture's Daily Transportation Commitment shall be suspended.

3.6 Maximum increase in throughput

If on any Day the quantities of Gas nominated by the Shipper for the following Day increase compared to the Shipper's nomination for the current Day to the extent that the nomination, in the Operator's sole opinion, cannot be honoured by Nyhamna Joint Venture due to a physical limitation to the total increase in the Transportation System throughput from one Day to another, Nyhamna Joint Venture's Daily Transportation Commitment shall be suspended.

4 OPERATING CONDITIONS AND QUALITY REQUIREMENTS

4.1 Requirements at the Entry Point(s)

For Gas entering Nyhamna Gas Plant at Entry Point P1, the operating conditions and quality specifications in article 7.1 shall apply (the “Specifications”).

For Gas entering Nyhamna Gas Plant at Entry Point P2, the operating conditions and quality specifications in article 7.2 shall apply (the “Specifications”).

In addition, the Gas shall be free from objectionable odours, materials, or liquid matter, waxes, gums and gum-forming constituents and dust or other solid matter which might cause damage to or interference with the proper operation of facilities through which it flows.

4.2 Requirements at the Exit Point(s)

For Gas being redelivered from the Nyhamna Gas Plant, the operating conditions and quality specifications in article 7.3 shall apply (the “Specifications”).

For Condensate being redelivered, the operating conditions and quality specifications in article 7.5 shall apply (the “Specifications”).

If the Operator redelivers or expects to redeliver Off-spec Gas to the Shipper, the Operator shall inform the Shipper as soon as possible.

4.3 Combination of Gas in order to meet the quality requirements

The Operator shall use reasonable endeavours to commingle Gas within the Transportation System and, if applicable, at the Exit Point(s) to ensure that the Specifications at the Exit Point(s) can be met.

The Operator shall advise the Shipper how to combine its sources of Gas in order to comply with the Specifications at the Entry Point(s) and the Exit Point(s). However, the responsibility to ensure such compliance stays with the Shipper.

4.4 Blending Service

4.4.1 Carbon dioxide blending

Notwithstanding article 4.1, if Shipper has sufficient Quality Blending Service for carbon dioxide, the Shipper shall have the right to deliver Off-spec Gas according to note 1 of article 7.2.

4.4.2 Hydrogen sulphide and COS blending

Notwithstanding article 4.1, if Shipper has sufficient Quality Blending Service for hydrogen sulphide and COS, the Shipper shall have the right to deliver Off-spec Gas according to note 2 of article 7.2.

4.5 Condensate product quality compensation

If Nyhamna Joint Venture redelivers to the Shipper Condensate at the Exit Point(s) in Area P that are outside the Specification at the Exit Point(s), then Nyhamna Joint Venture shall compensate the Shipper in accordance with article 10 in the Condensate Lifting Procedure.

The costs for such product quality compensation shall be carried by all shippers in Area P, including the Shipper, by including such costs as a share of the operational costs for the applicable service in Area P.

5 MEASUREMENTS, TESTS AND ANALYSES

5.1 General

Subject to governmental regulations, all measurement, testing, on-line analysis and sampling facilities and procedures necessary to monitor the Gas quality and perform allocation of Shipper's Gas according to article 6, shall be in accordance with this article 5. The procedures shall be made on the basis of high and consistent accuracy between measurement, test, on-line analysis and sampling of the Gas streams.

5.2 Measurements, tests and analyses at the Entry Point(s)

In order to monitor the operating conditions and the quality of the Gas to be delivered at the Entry Point(s), the Shipper shall carry out or cause to be carried out on its behalf necessary measurements, analyses and tests in the manner and frequency as requested by the Operator and shall have results from such measurements, analyses and tests transmitted to the Operator.

Relevant data and specifications for any measuring facilities required upstream the Entry Point(s) to perform such monitoring of the operating conditions and the quality of the Gas shall be subject to review by the Operator.

5.3 Measurements, tests and analyses at the Exit Point(s)

In order to monitor the operating conditions and the quality of the Gas redelivered at the Exit Point(s), the Operator shall carry out or cause to be carried out the necessary measurements, analyses and tests in the manner and frequency set by the Operator and shall make the results from such measurements, analyses and tests available to the Shipper if so requested.

5.4 Facilities upstream of the Entry Point(s)

Subject to last paragraph of this article 5.4 the Shipper shall, at its own expense, have or ensure to have measurement, testing, on-line analysis and/or sampling facilities installed maintained and operated upstream of the Entry Point(s). The design, installation and operation of said facilities shall be subject to approval by the Operator. Such approval shall not be unreasonably withheld or delayed.

The Shipper shall ensure that the Operator have access at reasonable times to said facilities to witness the calibrations and tests and to observe the operation of

the measurement, testing, on-line analysis and/or sampling facilities installed upstream the Entry Point(s). The Shipper shall furnish the Operator, at its request and for its audit, any and all metering data and other test information applicable to said facilities reasonably necessary for verification of the measurements contemplated in this article 5.4.

In the event the Shipper or the Shipper's Field Operator(s) experience a malfunction of its measurement, testing, on-line analysis and/or sampling facilities which may affect the accuracy of measurement, the Shipper shall ensure that the Shipper's Field Operator(s) as soon as practically possible advise the Operator of the same. In such a case, the Gas quantities delivered shall be estimated by the respective Shipper's Field Operator(s) and approved by the Operator. In the event that the malfunction prevents the Operator from properly allocating the received quantities to each shipper in accordance with article 6 and the malfunction cannot be corrected within a period of time acceptable to the Operator and as notified to the Shipper, then deliveries hereunder shall cease until such time as the malfunction has been corrected to the satisfaction of the Operator and the Operator has notified the Shipper that deliveries may be resumed.

5.5 Facilities downstream of the Entry Point(s)

The Operator shall arrange at its expense, with respect to all redeliveries from the Transportation System, to have all measurement, testing, on-line analysis and/or sampling facilities installed, operated and maintained downstream the Entry Point(s). All tests and other procedures according to this article necessary for allocation and accounting of Shipper's Gas in accordance with article 6 shall be performed in strict compliance herewith at each point where measurement, testing, on-line analysis and/or sampling facilities are installed in the Transportation System and/or any downstream receiving terminal(s) for allocation of Shipper's Gas.

Furthermore, at the request of the Shipper, the Operator will give reasonable notice to permit representatives of the Shipper to witness calibrations and tests, and to observe the operation of the relevant measurement, testing, on-line analysis and/or sampling facilities for allocation and accounting of Shipper's Gas and the Operator shall also furnish to the Shipper at its request and for its audit, any and all metering data and other analyses and testing information applicable to said facilities, reasonably necessary for the verification of the measurements contemplated in this article 5.5.

5.6 Design of measurement facilities

Subject to governmental regulations, the following principles shall apply for the metering equipment used for allocation of Shipper's Gas in the Transportation Systems.

The following related to the allocation of the Shipper's Gas, shall be measured fiscally;

- the mass of Gas for all deliveries to the Transportation System,

- the mass of Condensate delivered from the Transportation System, and
- the mass of Gas for all deliveries of Dry Gas from the Transportation System.

Fiscal metering systems shall be designed according to one of the following principles;

- orifice meters in accordance with ISO 5167,
- turbine meters for gas in accordance with ISO 9951 and AGA 7,
- turbine meters for liquids in accordance with API MPMS,
- ultrasonic meters according to relevant standards, or
- any other design agreed between the Operator and the shippers.

Any metering system shall be designed and constructed to have a high and consistent accuracy.

The design of any metering system to be used for the above purposes shall be approved by the Operator.

5.7 Maintenance and calibration

To ensure that measurement accuracy is maintained within tolerance limits, all measurement equipment shall be maintained and operated in accordance with;

- governmental regulations,
- applicable codes,
- manufacturer's specifications, and
- the Operator's requirements related to fiscal metering.

Tolerance limits for any specific equipment shall be specified on the basis of governmental regulations, manufacturer's specifications and operational experience.

Calibration tests of the measurement equipment shall be performed by methods and frequencies that the authorities, the Operator, and the relevant operator(s) of the Field(s), agree are adequate.

Any Shipper whose interests are affected by an error in measurement equipment may request the Operator to initiate special tests of the above measurement equipment in addition to the agreed regularly scheduled tests. The expense of any such special test shall be borne by the Shipper requesting such special test, unless such test shows that the systematic error in the total mass flow measurement, caused by component being in error or out of calibration, exceeds

0.4 per cent, in which case the expense of the special test shall be included as normal operating cost in the Transportation System.

If any measurement equipment is out of service and the quantity of Gas delivered is not correctly indicated by the reading thereof, the quantity delivered, during such period, shall be estimated by the operator of the measurement equipment in question on the basis of the best data available using the first of the following methods which is feasible;

- by using the registration of any check measuring equipment, or
- by correcting the error if the percentage of error is ascertainable by calibration, test or mathematical calculations, or
- by estimating the quantity of delivery by deliveries during preceding or subsequent periods under similar conditions when the measuring equipment was in service.

If any error in measuring equipment is found to affect quantities of mass being measured by not more than 0.02 per cent of total mass flow, previous recordings of such equipment shall be considered as being correct in measuring deliveries of Gas hereunder, but such equipment shall forthwith be adjusted to record accurately.

If any error in measuring equipment is found to affect quantities of mass being measured by an amount exceeding 0.02 per cent of total mass flow, then any previous recordings of such equipment shall be corrected for any period which is known, or agreed upon. If the period is not known or agreed upon, such corrections shall be for a period extending over one half of the time elapsed since the date of the last test. Such corrected readings shall be considered correct in measuring deliveries/ redeliveries of Gas hereunder.

5.8 Analysis

Analyses for allocation of Shipper's Gas shall be established by on-line chromatography, or by analysing flow proportional composite samples from the streams in question.

On-line gas chromatographs and flow proportional samplers shall be operated and maintained according to procedures developed by the Operator.

Any analysis to be used in the allocation Shipper's Gas shall be representative for the stream and time in question.

The gas shall be analysed by gas chromatography according to ASTM 1945 latest version, to determine the content in mole % of;

- nitrogen,
- carbon dioxide,
- methane,
- ethane,

- propane,
- iso-butane,
- normal butane,
- iso-pentane,
- normal pentane,
- hexanes and heavier components.

Due to the expected variations in flow and in gas composition, the resulting composition shall be flow weighted, either by performing flow proportional sampling, or by combining the analyses from online gas chromatographs with the flow as metered by the fiscal metering system.

When online gas chromatograph is used a daily flow weighted analysis shall be calculated. For allocation purposes a monthly flow weighted analysis shall be established and reported.

When flow proportional sampling is used, the samples shall be forwarded monthly to the Operator.

Sampling and shipping of sampling cylinders shall be performed according to procedures as developed by the Operator.

5.9 Codes and standards

Codes and standards to be used for measurement, test, on-line analysis and/or sampling of the Gas are subject to governmental regulations.

Listed below are codes which are generally accepted in the oil and gas industry, any of which may be used for the purpose herein. The Operator will inform the Shipper if a change to a newer version of any standard is prepared.

- NORSOK standard I-106
Fiscal metering systems for hydrocarbon liquid and gas.
- International Standard ISO 80000
Quantities and units.
- International Standard ISO 3171
Petroleum Liquids - Automatic Pipeline Sampling.
- International Standard ISO 5024
Petroleum Liquids and Liquefied Petroleum Gases - Measurement -Standard reference conditions.
- International Standard ISO 5167
Measurement of fluid flow by means of pressure differential devices inserted in circular cross-section conduits running full - Part I: General principles and requirements, Part 2: Orifice plates, Part 3: Nozzles and Venturi nozzles, Part 4: Venturi tubes.

- International Standard ISO 5168
Measurement of Fluid Flow – Procedure for the Evaluation of Uncertainty.
- International Standard ISO 6974
Natural Gas – Determination of composition with defined uncertainty by gas chromatography, Part 1: Guidelines for tailored analysis, Part 2: Measuring-system characteristics and statistics for processing of data, Part 3: Determination of hydrogen, helium, oxygen, nitrogen, carbon dioxide and hydrocarbons up to C8 using two packed columns, Part 4: Determination of nitrogen, carbon dioxide and C1 to C5 and C6+ hydrocarbons for a laboratory and on-line measuring system using two columns.
- International Standard ISO 6976
Natural Gas - Calculation of Calorific Values, Density, Relative Density and Wobbe Index from composition.
- International Standard ISO 9951
Measurement of gas flow in closed conduits - Turbine meters.
- International Standard ISO 10715
Natural Gas - Sampling Guidelines.
- International Standard ISO 10790
Measurement of fluid in closed conduits – Guidance to the selection, installation and use of Coriolis meters (mass flow, density and volume flow measurements).
- International Standard ISO 12213
Natural Gas - Calculation of compression factor, Part 1: Introduction and guidelines, Part 2: Calculation using molar-composition analysis.
- AGA-7
Measurement of Natural Gas by Turbine Meters – AGA Transmission Measurement Committee Report No. 7.
- AGA 8
Compressibility Factor of Natural Gas and Related Hydrocarbon Gases – AGA Transmission Measurement Committee Report No. 8.
- AGA 9
Measurement of Gas by Multipath Ultrasonic Meters – AGA Transmission Measurement Committee Report No. 9.
- AGA 10
Speed of Sound in Natural Gas and Other Related Hydrocarbon Gases – AGA Transmission Measurement Committee Report No. 10.
- AGA 11
Measurement of Natural Gas by Coriolis Meter – AGA Transmission Measurement Committee Report No. 11.

- ASTM D-1945
Analysis of Natural Gas by Gas Chromatography.
- ASTM D-3700
Standard Test Method for Obtaining Hydrocarbon Fluid Samples Using a Floating Piston Cylinder.
- GPA Publication 2166
Methods for Obtaining Natural Gas Samples for Analysis by Gas Chromatography.
- API Manual of Petroleum Measurement Standards
Chapter 14 - Natural Gas Fluids Measurement.
- ISO 17089-1
Measurement of fluid flow in closed conduits - Ultrasonic meters for gas - Part 1: Meters for custody transfer and allocation measurement

6 ALLOCATION OF SHIPPER'S GAS

6.1 General

6.1.1 Preliminary reporting

The Operator shall report the metered quantities and the calculations of the Shipper's Gas to the Shipper within the 7th Business Day of the succeeding Month. The report may be postponed if the mass and analysis result as described in article 6.2.2 second paragraph is issued later than the 1st Business Day of the Month succeeding the Month in which the analysis was taken. The standards and practices applicable to the metering and analysis in article 5 shall apply for the allocation calculations.

6.1.2 Final reporting

The Operator shall report the final metered quantities and the calculations of the Shipper's Gas to the Shipper within the 7th Business Day of the next succeeding Month. The standards and practices applicable to the metering and analysis in article 5 shall apply for the allocation calculations.

6.1.3 Reallocation

In case of errors as described in article 5.7 last paragraph and/or in case errors in the Operator's system that affect the Shipper and/or errors discovered in audits performed by the Shipper or on behalf of the Shipper, reallocation shall be performed by adjustments to the actual Month. However, no reallocation shall adjust any Months more than 24 Months before the start of the current calendar year.

In case of errors having occurred more than 24 Months before the start of the current calendar year, the Operator decides how reallocation shall be performed, normally by adjustments to the last 24 Months. The Operator may, in its sole opinion, decide not to perform reallocation for errors having occurred more than

24 Months before the start of the current calendar year if the cost for such reallocation exceeds the value of the error or otherwise is unreasonable, in so far as this is in accordance with applicable legislation. Operator's decision according to this article 6.1.3 is final.

6.1.4 Yearly reallocation

The Operator will report adjustments to the final metered quantities during the first half of the succeeding year taking into account any reporting from the shippers after the final reporting as described in article 6.1.2. In case of significant errors the Operator may perform a reallocation during the year.

6.2 Gas allocation

Gas allocation is further described in the Shipper Manual.

6.2.1 Measurement scheme

The measurement scheme comprises measurement facilities at each of the Fields delivering Gas into the Transportation System and at each Exit Point.

A principle sketch of the allocation scheme is shown in the figure below.

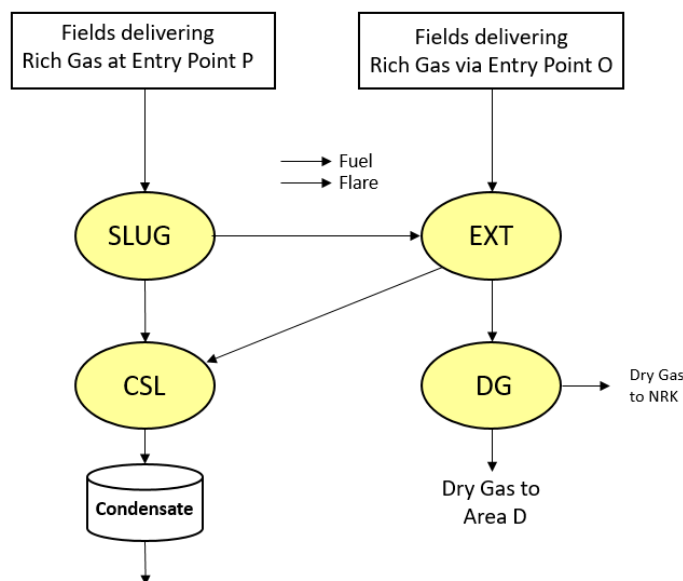

6.2.2 Measuring, sampling and analysis

The Operator shall determine the total mass of each separate Gas stream mentioned in article 6.2.1. The total mass of each stream of Condensate shipped from the Transportation System shall be determined by the Operator by metering the mass during loading of vessels.

The Shipper shall, if requested by the Operator, ensure that a verified mass and a representative analysis is obtained from each of the streams from the Shipper's Field(s) to determine the Components and any other substances as may be required for purposes of allocation of Shipper's Gas. Such mass and analysis

results shall be issued to the Operator within the 1st Business Day of the Month succeeding the Month in which the analysis was undertaken.

The Shipper shall ensure that the result of sample analysis at the Shipper Field(s) is reported to the Operator for each Component as described in article 5. The Operator shall use the result of such analysis for accounting and allocation purposes.

The Operator shall for all calculations herein set the properties of combined hexanes and heavier hydrocarbons equal to normal hexane.

6.2.3 Allocation of Components

The streams from the Shipper's Field(s) shall be metered and analysed in accordance with article 6.2.1 during each Accounting Period. The mass of each of the individual Components in a stream shall be equal to the total mass of such stream multiplied by the mass fraction of each Component.

The Shipper's fractional share of a Component for each Shipper's Field(s) in a commingled stream shall be the mass of that Component in the input stream from the Shipper's Field(s), divided by the total mass of that Component for all input streams entering and becoming a part of the commingled streams.

When a commingled stream is split into two or more separate streams, the Shipper's fractional share of a Component for each Shipper's Field(s) shall remain the same in each such separate stream.

The Shipper's fractional share for each Shipper's Field(s) shall also apply to the output streams.

The Shipper's allocation percentage of the Shipper's fractional share for each Shipper's Field(s) shall be based on the Daily Nominations provided by the Shipper for the Shipper's Field(s).

In cases where there are no shipper nomination in respect of a Field the Operator will use an allocation key provided by the field operator.

6.2.4 Fuel Gas, Gas to flare and Replacement Gas

The Shipper shall ensure that fuel gas requirements at the Shipper's Field(s) shall be withdrawn upstream of the Gas metering facilities. In the event Gas is withdrawn or vented downstream of the metering facilities, it shall be appropriately accounted for by procedures approved by the Operator.

Fuel Gas and Gas to flare withdrawn in the Transportation System shall be accounted for and debited the Shipper in accordance with article 6.2.3.

Where determinable losses occur, Replacement Gas shall be accounted for and debited the Shipper in accordance with article 6.2.3.

6.2.5 Shipper failing to lift Condensate

Product flaring in connection with the Shipper failing to lift Condensate shall be treated as a "lifting" for the Shipper.

7 TABLES

7.1 Entry specifications for Gas entering Area P at Entry Point P1

Designation and unit	Specification	Notes
Maximum operating pressure (barg)	135	
Minimum operating pressure (barg)	84	1
Maximum operating temperature (°C)	50	
Minimum operating temperature (°C)	-14	
Maximum water production (Sm ³ /day)	430	
Max. daily average Monoethylene glycol production (Sm ³ /day)	1500	
Maximum carbon dioxide (mole %)	0,37%	
Maximum hydrogen sulphide (ppm vol)	0,5	
Maximum O ₂ (ppm vol)	None	
Max. daily average methanol content (ppm vol)	0	

- (1) Pressure requirement at blending point where gas from Entry Point P1 is comingled with gas from Entry Point P2, measured at the inlet of the turbo expanders.

7.2 Entry specifications for Gas entering Area P at Entry Point P2

Designation and unit	Specification	Notes
Maximum operating pressure (barg)	210	
Minimum operating pressure (barg)	115	
Maximum operating temperature (°C)	50	
Minimum operating temperature (°C)	-10	
Maximum hydrocarbon dewpoint (barg at 0°C)	110	
Maximum water dew point (°C at 70 bara)	-18	
Maximum carbon dioxide (mole %)	2.3	1
Maximum hydrogen sulphide and COS (ppm vol)	3.0	2
Maximum oxygen (ppm vol)	None	
Maximum daily average methanol content (ppm vol)	0	

- (1) Subject to article 4.4.1, the maximum CO₂ is 8.00 mole %.
- (2) Subject to article 4.4.2, the maximum sum of hydrogen sulphide and COS is 12 ppm (vol).

7.3 Exit specifications for Gas being redelivered at Exit Point P1

Designation and unit	Specification	Notes
Maximum operating pressure (barg)	248	
Maximum operating temperature (°C)	50	
Minimum operating temperature (°C)	-10	
Hydrocarbon dewpoint (°C at 50 barg)	< -10	
Water dew point (°C at 69 barg)	-18	
Maximum carbon dioxide (mole %)	2.50	
Maximum oxygen (ppm vol)	2	
Maximum hydrogen sulphide incl. COS (mg/Nm ³)	5	
Maximum mercaptans (mg/Nm ³)	6.0	
Maximum sulphur (mg/Nm ³)	30	
Gross Calorific Value (MJ/Sm ³)	38.1 - 43.7	
Gross Calorific Value (MJ/Nm ³)	40.2 - 46.0	
Gross Calorific Value (kWh/Nm ³)	11.17 - 12.78	
Wobbe Index (MJ/Sm ³)	48.3 - 52.8	
Wobbe Index (MJ/Nm ³)	51.0 - 55.7	
Wobbe Index (kWh/Nm ³)	14.17 - 15.47	

7.4 Exit specifications for Gas being redelivered at Exit Point P2 (Gas Power Plant)

Designation and unit	Specification	Notes
Maximum operating pressure (barg)	92.5	
Minimum operating pressure (barg)	27.5	
Maximum operating temperature (°C)	50	
Minimum operating temperature (°C)	-10	
Hydrocarbon dewpoint (barg at 50 °C)	< -10	
Water dewpoint (°C at 69 barg)	-18	
Maximum carbon dioxide (mole %)	2.50	
Maximum oxygen (ppm vol)	2	
Maximum hydrogen sulphide incl. COS (mg/Nm ³)	5	
Maximum mercaptans (mg/Nm ³)	6.0	
Maximum sulphur (mg/Nm ³)	30	
Gross Calorific Value (MJ/Sm ³)	38.1 - 43.7	
Gross Calorific Value (MJ/Nm ³)	40.2 - 46.0	
Gross Calorific Value (kWh/Nm ³)	11.17 - 12.78	
Wobbe Index (MJ/Sm ³)	48.3 - 52.8	
Wobbe Index (MJ/Nm ³)	51.0 - 55.7	
Wobbe Index (kWh/Nm ³)	14.17 - 15.47	

7.5 Exit specifications for Condensate being redelivered at Exit Point P3

Component weight %	
Total Oxygenate (TEG, MEG, methanol)	10 ppmw max
Water content	No free
TVP bara (@30°C)	0.965 max
RVP bar (@38°C)	0.79 max
Basic Sediment and Water (vol %)	0.5 max

APPENDIX B

TO

TERMS AND CONDITIONS FOR

TRANSPORTATION OF GAS

AT NYHAMNA GAS PLANT

TRANSPORTATION SYSTEM DESCRIPTION

TABLE OF CONTENTS

1	Description	3
1.1	Nyhamna Gas Plant	3
2	Quality Blending Services Description	3
2.1	Quality Blending Service.....	3
3	Entry Points and Exit Points	3
3.1	Entry and Exit Points.....	3
3.2	Entry Points	4
3.3	Exit Points	6

1 Description

1.1 Nyhamna Gas Plant

Nyhamna Gas Plant comprises the gas plant for processing and handling of Rich Gas, Condensate and storage/redelivery of the products. The services included are:

- Extraction (“EXT”) which extracts Rich Gas and delivers Dry Gas and Condensate at the Exit Point(s).
- Carbon Dioxide Blending (“CO₂ B”) which blends Off-Spec Gas, related to carbon dioxide, with other Gas.
- Hydrogen Sulphide and COS Blending which blends Off-Spec Gas, related to hydrogen and COS, with other Gas.

2 Quality Blending Services Description

2.1 Quality Blending Service

Quality Blending Service shall mean the services where Nyhamna Joint Venture takes on a reasonable endeavour obligation to blend the Gas in order to meet the Specification at the Exit Point. Quality Blending Service is provided for CO₂ and H₂S/COS blending.

3 Entry Points and Exit Points

3.1 Entry and Exit Points

The Entry Points at which the Shipper shall deliver Gas to Nyhamna Joint Venture are as defined in articles 3.2.

The Exit Points at which Nyhamna Joint Venture shall redeliver Gas to the Shipper are as defined in articles 3.3.

3.2 Entry Points

3.2.1 Entry Point P1 from Ormen Lange

The Entry Point P1 is immediately after the Landfall Bund upstream the ESD valves (EV-16-1001 and EV-16-2001) for pipeline A and pipeline B as shown in figure 3.2.1.

Figure 3.2.1

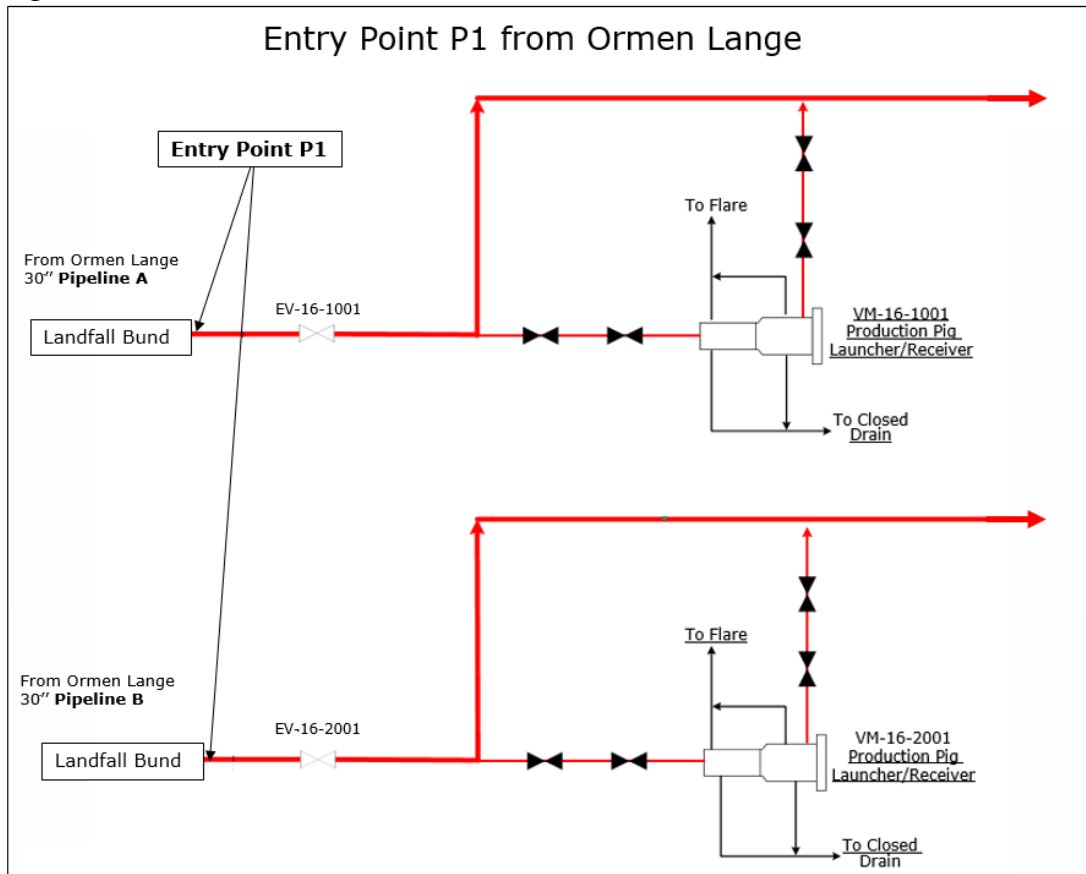

3.2.2 Entry Point P2 from Polarled

The Entry Point P2 is immediately after the Landfall Bund upstream the ESD valve (EV-16-4021) as shown in figure 3.2.2.

Figure 3.2.2

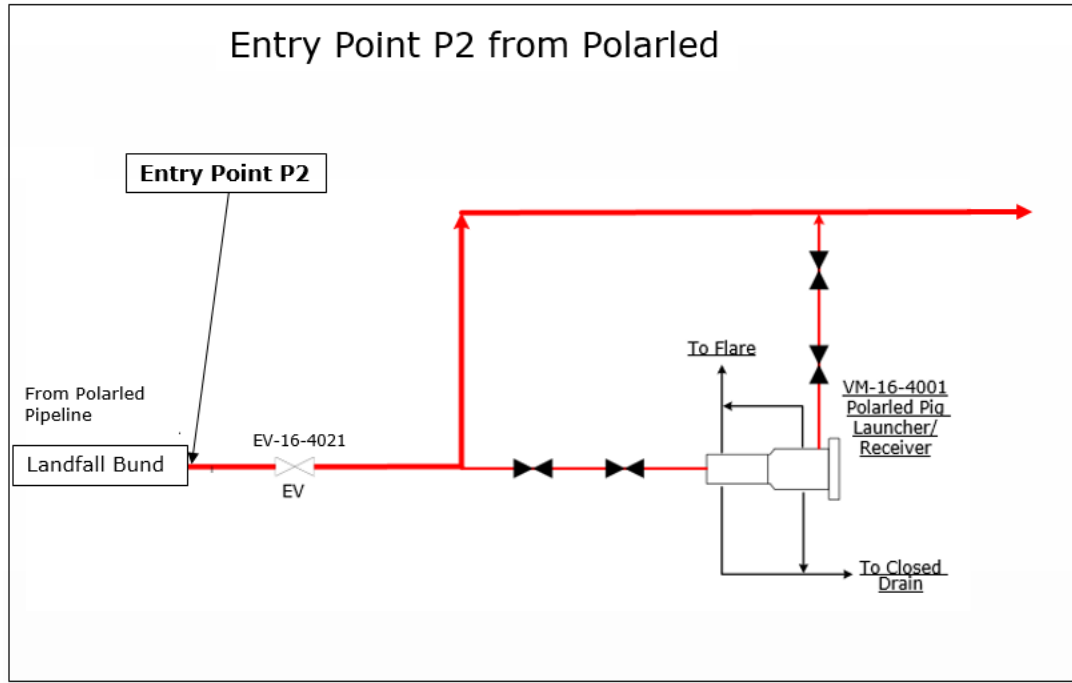

3.3 Exit Points

3.3.1 Exit Point P1 to Gassled

The Exit Point P1 is immediately before the Landfall Bund downstream of the ESD valve (EV-27-4912) as shown in figure 3.3.1.

Figure 3.3.1

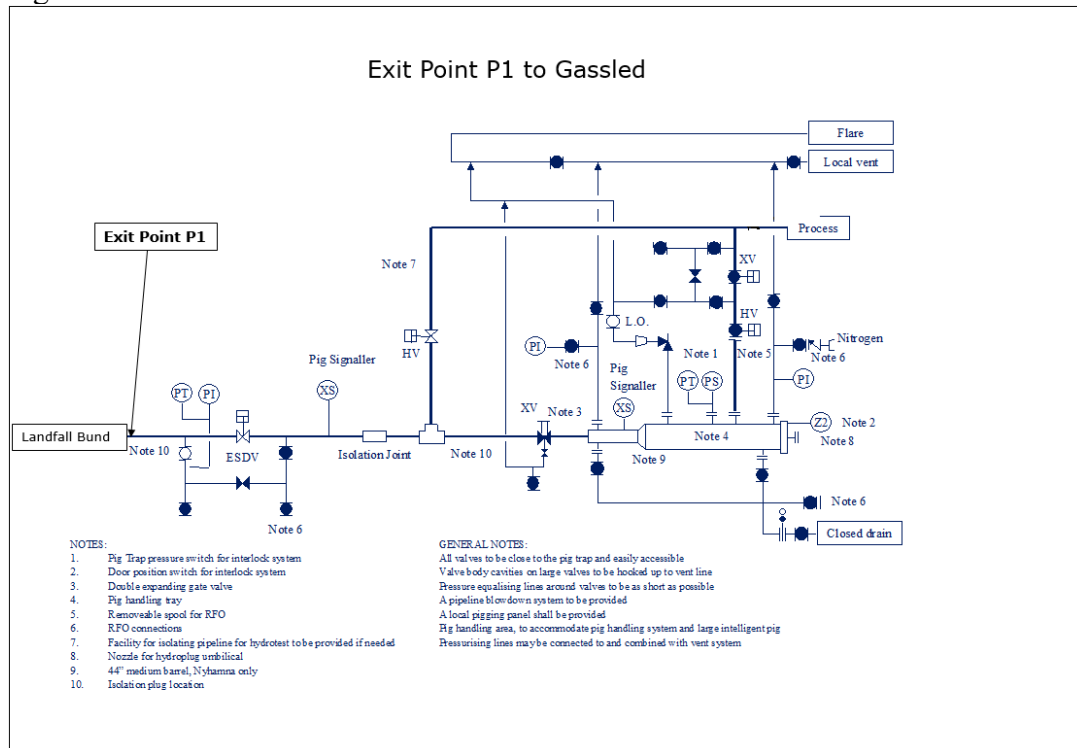

3.3.2 Exit Point P2 to Gas Power Plant

The Exit Point P2 is at the flange between the Emergency Valve (EV-27-0384) and the Throttle valve as shown in figure 3.3.2.

Figure 3.3.2

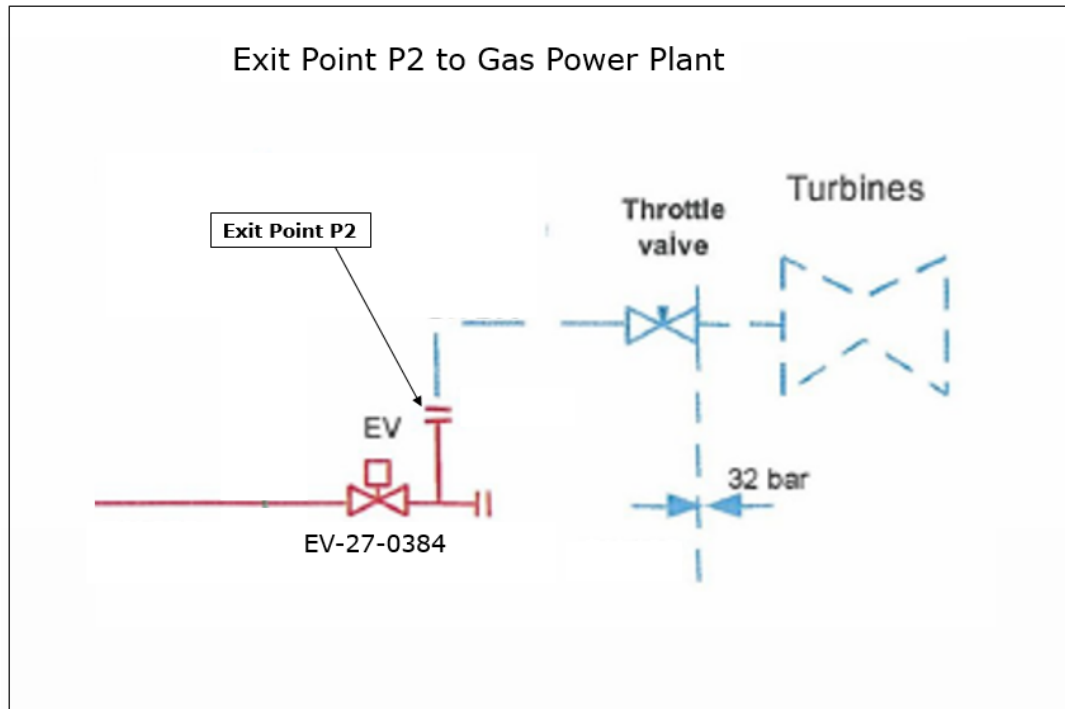

3.3.3 Exit Point P3 for Condensate

The Exit Point P3 is at the flange/coupling connection between the loading arm at the loading berth of Nyhamna Gas Plant, and the manifold on the loading vessel.

APPENDIX C

TO

TERMS AND CONDITIONS FOR PROCESSING OF GAS AT NYHAMNA GAS PLANT

CONDENSATE LIFTING PROCEDURE

TABLE OF CONTENTS

1	APPLICABILITY AND DEFINITIONS	4
1.1	Applicability	4
1.2	Definitions	4
2	CONDENSATE FORECASTS	6
2.1	Long term forecasts of Condensate redeliveries	6
2.2	Shipper's Condensate Availability and lifting.....	6
2.3	Condensate account	6
2.4	Shipper's responsibility	6
3	NOMINATION PROCEDURE	6
3.1	Condensate Availability	6
3.2	Lifting nominations	7
3.3	Lifting Programme	7
3.4	Final Nomination	8
3.5	Vessel's ETA	9
3.6	Conflicting nominations handling	9
3.7	Correspondence and Contact Personnel	9
3.8	Independent surveyors.....	10
3.9	Combined lifting arrangements	10
4	LIFTING OBLIGATIONS	11
4.1	Working Storage Capacity	11
4.2	Disposal of excess Condensate in case of higher production than forecasted	11
4.3	Disposal of excess Condensate due to late arrival of vessel or Shipper's failure to lift	12
4.4	Disposal of excess Condensate due to other reasons	12
5	VESSEL	12
5.1	Nyhamna Gas Plant regulations.....	12
5.2	Vessel acceptance and clearance.....	13
5.3	Replacement of nominated vessel.....	13
5.4	Nomination outside limitations	13
6	LOADING CONDITIONS AND REGULATIONS	13
6.1	Notice of Readiness	13
6.2	Laytime allowances.....	14
6.3	Adjustment of laytime allowances, used laytime and time on demurrage.....	14
6.4	Cessation of laytime or time on demurrage	15
6.5	Demurrage	15
6.6	Demurrage claims	16
6.7	Harbour fees and expenses.....	16
6.8	Inspection of vessel.....	16
7	BERTHING PRIORITY	17
7.1	Arrival within set range	17
7.2	Arrival before set range.....	17
7.3	Arrival after Date Of Loading.....	17
7.4	The Operator's right.....	17

8	DOCUMENTATION PROCEDURE.....	17
8.1	Introduction.....	17
8.2	Standard set of documents	18
8.3	Early departure.....	20
8.4	Other documents	20
8.5	Documentation related to Part Cargoes	20
9	QUANTITY CORRECTION PROCEDURE	20
9.1	Quantities and Vessel Experience Factor.....	20
9.2	Variance between quantities.....	21
10	QUALITY COMPENSATION PROCEDURE.....	23
10.1	Introduction.....	23
10.2	Documentation and information.....	23
10.3	Compensation and claims handling.....	23
10.4	Payment and accounting	23

1 APPLICABILITY AND DEFINITIONS.

1.1 Applicability

This Condensate Lifting Procedure sets out the operational regulation regarding the Shipper's and Nyhamna Joint Venture's rights and obligations given in the Terms and Conditions.

The Operator will execute Nyhamna Joint Venture's rights and obligations according to this Condensate Lifting Procedure.

1.2 Definitions

The definitions set out in the Terms and Conditions applies to this Condensate Lifting Procedure. In addition, the following terms shall have the meaning ascribed to them below:

1. "Barrel" shall mean 42 U.S standard gallons corrected to 60 Degrees Fahrenheit.
2. "Bill Of Lading" shall mean the receipt for the Cargo(es) or Part Cargo(es), and contains among other the quantity loaded for the Shipper.
3. "Cargo" shall mean the quantity of Condensate nominated by the shipper/shippers to be loaded on to a vessel and given a single Cargo Reference Number. A Cargo may include two or more Part Cargoes.
4. "Cargo Documents" shall mean the documents described in article 8.
5. "Cargo Reference Number" shall mean a sequential number determined by the Operator for each Cargo nominated.
6. "Condensate Availability" shall have the meaning as described in article 3.1.
7. "Date Of Loading" shall mean the date of loading given by the Operator in the Lifting Programme as a single date, to be understood as the date with a 24 hours range on each side of the date (3 day period). When the procedure refers to Date Of Loading as one single date this shall mean the date given by the Operator in the Lifting Programme.
8. "Effective Valve Closing Time" shall mean the time required to close the valve if the maximum rate of closure is applied to cover the full stroke.
9. "ETA" shall mean Estimated Time of Arrival for a vessel.
10. "Harbour Regulations" shall mean the "Nyhamna Harbour Regulations and Information Guide Nyhamna Marine Terminal" as amended from time to time.
11. "Lifting Programme" shall mean the lifting schedule determined by the Operator in accordance with article 3.3.

12. "Master" shall mean the captain on Shipper's vessel.
13. "Metric Ton" shall mean Metric Ton in vacuum.
14. "Month A" shall mean any of the years 12 months. Month B, C etc. is the following months.
15. "Notice of Readiness" shall have the meaning as described in article 6.1.
16. "Overlift" shall mean the quantities the Shipper has lifted more than its Condensate in storage.
17. "Part Cargo" shall mean a quantity of Condensate nominated by the Shipper to be loaded on a vessel together with other Part Cargoes nominated by the Shipper or by another shipper. Part Cargoes will always have the same main Cargo Reference Number.
18. "Underlift" shall mean the quantities the Shipper has lifted less than its Condensate in storage.
19. "Working Storage Capacity" shall mean the total storage capacity for Condensate, less bottoms and safety margins as determined by the Operator.

2 CONDENSATE FORECASTS

2.1 Long term forecasts of Condensate redeliveries

Based on information provided by the Shipper pursuant to the Operation Manual article 2.1, the Operator shall twice a year give to the Shipper the estimated quantities of Condensate to be redelivered from the Nyhamna Gas Plant in each Month for the current and the next Year, in each quarter for the next succeeding three Years, and in each year for the remaining Years.

2.2 Shipper's Condensate Availability and lifting

In the manner provided in article 3, the Operator will notify the Shipper of the Condensate Availability and the Shipper will nominate and lift such quantities of Condensate as may be required to keep its product account in balance as closely as feasible, giving due regard to the practical necessity of making available parcel sizes consistent with any vessel size within the ranges as defined in the Harbour Regulation. The Shipper will be permitted to lift more or less of its estimated Condensate Availability within reasonable limits as long as the Overlift or Underlift otherwise meet the requirements of this Condensate Lifting Procedure and is in no way detrimental to the operation of the Nyhamna Gas Plant and / or the requirements of the other shippers.

2.3 Condensate account

The Operator shall maintain a separate Condensate account for the Shipper showing the quantity of Condensate allocated or transferred for the account of the Shipper, and debited with the quantity of Condensate lifted, transferred from, or otherwise disposed of, on behalf of the Shipper. Adjustments in accordance with article 9 shall also be reflected in the account.

The Shipper may transfer a product in storage to another shipper and the product account will be updated accordingly. If both shippers confirm the transaction within the 8th Business Day of Month A in the system designated by the Operator it will be included in the Condensate Availability for Month C. The Operator will not maintain accounts of loan or exchange between the shippers.

2.4 Shipper's responsibility

The Shipper shall ensure that this Condensate Lifting Procedure is followed in every respect for its Cargoes loaded, regardless of whether that Cargo is loaded by the Shipper itself or by a Third Party.

3 NOMINATION PROCEDURE

3.1 Condensate Availability

No later than the 10th Business Day of Month A, the Operator will advise the Shipper of its estimated Condensate Availability for Month C, taking into account all relevant factors, including the forecasted production for Month A, B and C for the Shipper and the estimated Underlift or Overlift position of the

Shipper at the end of Month B. At the same time, the Operator will advise the Shipper of its Condensate Availability for Months D and E, such quantities will be based on the assumption that there are no Overlift or Underlift at the end of Month C.

3.2 Lifting nominations

3.2.1

No later than the 23 day of Month A, the Shipper shall advise the Operator of its lifting nomination for Month C; and provide to the Operator the following information for each Cargo:

- A. Quantity to be loaded in Metric Ton.
- B. Preferred Date Of Loading.
- C. Information about Part Cargo

Quantity to be nominated shall not be less than 30 000 Metric Ton and not more than 100 000 Metric Ton. The Operator may accept to deviate from these limits.

If the Shipper does not intend to make a nomination for its Condensate Availability, the Shipper shall so advise the Operator.

3.2.2

If the Shipper fails to notify in accordance with article 3.2.1 the Shipper shall be deemed to have declined to make any nomination for its Condensate Availability, however always subject to article 3.2.3.

3.2.3

If in the Operator's opinion, the storage situation may affect the operation of the Nyhamna Gas Plant and the Shipper has declined, to make any nomination for its Condensate Availability in accordance with article 3.2.1, then the Shipper may be deemed to have nominated all or part of such Condensate Availability. The Operator shall decide when such Condensate Availability shall be lifted and will advise the Shipper accordingly. The Operator's decision will be final.

3.3 Lifting Programme

3.3.1

The Shipper's lifting nominations in accordance with article 3.2, will be balanced against the lifting programme and the Operator will, not later than the 28th day of Month A, confirm to the Shipper whether or not its lifting nomination is acceptable.

In case the lifting nomination is not acceptable, the Shipper will be informed of the necessary modifications. Such modifications may be required for technical or operational reasons or in the event of conflict with other shippers' nominations. Any lifting decided by the Operator in accordance with article 3.2.3 shall be included in the Lifting Programme.

The Operator will advise the Shipper of the Date Of Loading, the quantity and the Cargo Reference Number allocated to each Cargo.

3.3.2

If requested by the Shipper the Operator may deviate from the Lifting Programme if practicable and it is not considered detrimental to the operation of the Nyhamna Gas Plant or the nominations of other shippers. When assessing a request for deviation from the Lifting Programme, the Operator will among other consider operational issues such as for example jetty and storage availability and the Shipper's status with respect to Overlift or Underlift.

If the Operator, upon the Shipper's request accepts to deviate from the Lifting Programme, Nyhamna Joint Venture shall not be liable for any cost incurred as a result of the deviation from the Lifting Programme in connection with such lifting.

To the extent two (or more) shippers' nominated liftings for any reason are expected to conflict, a shipper which lifts in accordance with its Lifting Programme shall be given priority before a shipper which deviates from its Lifting Programme.

3.3.3

The Operator may, at its discretion due to technical or operational reasons, revise the Lifting Programme. The Operator will keep the Shipper informed about any subsequent changes to the Lifting Programme.

3.4 Final Nomination

3.4.1

Not less than 10 days before Date Of Loading, the Shipper shall for each Cargo and/or Part Cargo confirm its final nomination to the Operator advising the following details:

- A. The Cargo Reference Number.
- B. Date Of Loading as per the Lifting Programme.
- C. The quantity to be loaded in Metric Ton. The Cargo quantity must not vary by more than plus or minus 10 per cent from the quantity confirmed in the Lifting Programme. However, for Cargoes above 70 000 Metric Ton the quantity must not vary by more than plus or minus 5 per cent from the quantity confirmed in the Lifting Programme.
- D. The name of the vessel if available. However, the Operator must receive the name of the vessel not less than 5 days before the Date Of Loading. The vessel must be properly cleared and accepted by the Operator in accordance with article 5 within the same date.
- E. Final documentation instruction, including consignee and destination, if available. However, the Operator must receive the documentation instruction,

including consignee and destination, at least 2 Business Days before Date Of Loading.

3.4.2

If a Shipper fails to conform to the final nomination requirements in accordance with article 3.4.1 any cost and consequences will be for the Shipper's account. The previous sentence shall apply for all Part Cargos on the vessel if other shippers on the same vessel have not complied with the final nomination requirements in respect of their Part Cargos.

3.5 Vessel's ETA

After the final nomination has been made in accordance with article 3.4, if it becomes apparent that the vessel's ETA is expected to be outside the Date Of Loading the Shipper shall immediately advise the Operator. In the same manner, the Operator will immediately advise the Shipper of any events at the Nyhamna Gas Plant which might prevent or delay vessels loading on the Date Of Loading.

The Shipper shall advise of the vessel's ETA 7 days, 72, 48, 24 and 12 hours prior to the arrival along with all other information required in the Harbour Regulations. After the initial notification has been made, any change in ETA of more than 12 hours must immediately be advised to the Operator.

If a vessel arrives at the Nyhamna Gas Plant and the Shipper wants to start loading before the Date Of Loading, a request of this must be issued. The Operator will decide from case to case whether the above mentioned request can be effectuated or not.

All notices required according to this article shall conform with the applicable regulations in the Harbour Regulations and must be addressed by the vessel to the vessel's agent, who shall forward this information to the Operator in writing.

3.6 Conflicting nominations handling

In the event that the Operator is unable to accommodate conflicting nominations of two or more shippers, the shipper with highest Underlift at the anticipated date of loading shall be allocated such Cargo. The Operator's decision will be final.

3.7 Correspondence and Contact Personnel

3.7.1

All nominations described in this Condensate Lifting Procedure shall be done by using the system designated by the Operator.

Where a particular day or date is specified in this Condensate Lifting Procedure for receipt of nominations (article 3.4), and this day or date falls on a day that is not a Business Day, such nominations must be received by the Operator by the last Business Day prior to the day or date specified.

In the event that electronic transfer of data is impossible, then nominations may be made by telephone or by e-mail to the person(s) indicated in article 3.7.2. Verbal nominations shall be confirmed electronically at the first practical opportunity.

3.7.2

All nominations, other correspondence and general queries concerning any aspect of this Condensate Lifting Procedure shall be addressed to the Operator with the following contact details:

Telephone number + 47 52 81 25 80
Switchboard number + 47 52 81 29 46

E-mail shipplan@gassco.no

Outside normal office hours (08:00 to 15:45 hours), or on a day that is not a Business Day all urgent matters which must be dealt with before the next available Business Day, should be handled with the Transport Control Centre at Bygnes with the following contact details:

Telephone number + 47 52 81 28 95.

This should be followed up by written communication.

Similarly, the Shipper shall keep the Operator regularly advised of those persons within the Shipper's organisation who can be contacted outside normal office hours.

3.8 Independent surveyors

Shipper shall have the right to appoint an independent surveyor at its own cost and expense to verify the quantity and quality of Condensate lifted by the Shipper.

3.9 Combined lifting arrangements

The Shipper must inform the Operator about establishing or termination of combined lifting arrangements with other shipper(s) within the 1st Business Day of Month A in order to have it included in the Lifting Programme for Month C and onwards. Such information shall include information related to the shipper authorised to act on behalf of the shippers with regards to notices in accordance with this Condensate Lifting Procedure.

The Operator shall consider the combined Underlift/Overlift for the involved shippers also when handling conflicting nomination in accordance with article 3.6.

4 LIFTING OBLIGATIONS

4.1 Working Storage Capacity

The Condensate production at the Nyhamna Gas Plant is dependent on the production from offshore fields and production at the offshore fields is dependent on the at any time available storage capacity at the Nyhamna Gas Plant. All shipments of Condensate from the Nyhamna Gas Plant must therefore be scheduled to control storage within the Working Storage Capacity.

4.2 Disposal of excess Condensate in case of higher production than forecasted

If at any time, in the opinion of the Operator, circumstances indicate a potential shutdown of Condensate production due to storage above the Working Storage Capacity caused by higher production than forecasted, the following shall apply:

- i) The Operator shall notify all shippers of the situation as early as possible and request the shipper with the highest Underlift to lift the approximate quantities of Condensate as may be required.
- ii) In event the Shipper if requested according to i) above, fails to relieve the excess storage situation within a reasonable time period, taking into account the prevailing circumstances, the Operator shall take whatever steps may be necessary to reduce the storage situation down to the Working Storage Capacity prevailing at the time. The remedies available to the Operator includes the right to adjust the Lifting Programme, to sell or otherwise dispose of the excess Condensate. In the event that it becomes necessary to dispose of excess Condensate in accordance with the foregoing, the shippers will - whenever time permits - be given prior notice of such action and in any event, the Operator will keep the Shipper advised of any action taken to relieve the excess storage situation.
- iii) The excess Condensate disposed of by the Operator in the manner provided in ii) above shall be debited to the product accounts of those shippers which, at the end of that Month, would have been in Underlift position in the proportion that each shipper's excess product account balance bears to the sum of all shippers' excess product account balances.
- iv) The Operator shall charge in the same proportions, any direct documented costs incurred as a result of actions under ii) above to those shippers who are debited the Condensate in iii) above. Any revenue resulting from such disposal shall be credited in the same manner.

4.3 Disposal of excess Condensate due to late arrival of vessel or Shipper's failure to lift

If at any time, in the opinion of the Operator, circumstances indicate a potential shutdown of production caused by an anticipated late arrival of Shipper's vessel or Shipper's failure to lift, the following shall apply:

- i) The Operator shall notify the Shipper of the situation and the consequences thereof and ask the Shipper what remedies the Shipper will use to relieve the situation.
- ii) In the event the Shipper fails to relieve the excess storage situation within a reasonable time period taking into account the prevailing circumstances, the Operator shall take whatever steps may be necessary to reduce the high storage situation down to the Working Storage Capacity prevailing at the time. The remedies available to the Operator includes the right to sell or otherwise dispose of the excess Condensate. In the event that it becomes necessary to dispose of excess Condensate in accordance with the foregoing, the Shipper will - whenever time permits - be given prior notice of such action and in any event, the Operator will keep the Shipper advised of any action taken to relieve the excess storage situation.
- iii) All quantity disposed of in accordance with ii) above shall be debited to the product account of the Shipper, but not greater than the quantity nominated by the Shipper in accordance with article 3.4.1.
- iv) Any documented cost incurred as a result of actions under ii) above shall be charged to the Shipper. Any revenue resulting from such disposal shall be credited to the Shipper.

4.4 Disposal of excess Condensate due to other reasons

If at any time, in the opinion of the Operator, circumstances indicate a potential shutdown of production due to other causes than mentioned in articles 4.2 and 4.3, provisions of article 4.2 shall apply as relevant.

5 VESSEL

5.1 Nyhamna Gas Plant regulations

The Shipper must comply with the provisions of the Harbour Regulations.

For vessels nominated to lift Condensate the Shipper shall ensure that the vessels arrive in fully inerted condition and in every respect ready to load as specified in the Harbour Regulations.

5.2 Vessel acceptance and clearance

Vessels intended to be used for lifting at the Nyhamna Gas Plant shall be accepted by the Operator. The Operator shall confirm acceptance or rejection as soon as practicable possible but no later than within 2 Business Days. The Shipper must thereafter clear the vessel through the system designated by the Operator.

5.3 Replacement of nominated vessel

Notwithstanding article 3.4.2, the Shipper shall have the right to replace a properly nominated vessel with another vessel, provided that Date Of Loading and Cargo quantity to be loaded conforms with the information given in accordance with article 3.4 and the substituted vessel is properly cleared and accepted in accordance with article 5.2. Such replacement should be notified to the Operator at least 1 Business Day prior to ETA. The Operator may under special circumstances allow substitution of a vessel on shorter notice.

5.4 Nomination outside limitations

In the event the Shipper wishes to nominate a vessel outside the limitations listed in the Harbour Regulations, then the Shipper must contact the person(s) indicated in article 3.7.2 to determine whether or not the vessel might be accepted for loading at the Nyhamna Gas Plant.

6 LOADING CONDITIONS AND REGULATIONS

6.1 Notice of Readiness

6.1.1

Upon arrival of the vessel at the Nyhamna Gas Plant, or at the anchorage in the Nyhamna Gas Plant area, the Master or vessel's agent will notify the Operator or its representative, by radio or other electronic communication as approved by the Operator, that the vessel is ready in all respects to receive the Cargo. Notice of Readiness shall not be considered received before 06:01 on the tendered Day of the Date Of Loading. Laytime shall begin to run from 6 hours after such Notice of Readiness has been received, or upon the vessel being all fast ("completed mooring"), alongside the berth, whichever first occurs, provided that the vessel arrives and tenders Notice of Readiness within the Date Of Loading. The Operator's signature on the Notice of Readiness only indicate receipt of the document and not an acceptance of the vessel as ready to load.

The vessel will not be considered to have tendered Notice of Readiness, unless such vessel is completely ready, in all aspects, and in accordance with the provisions of the Harbour Regulations to receive the Cargo for which the vessel has been properly nominated.

In the event that the vessel is delayed in berthing after tendering Notice of Readiness as above due to restrictions at the Nyhamna Gas Plant, the vessel shall

maintain its status as ready to load throughout the period of delay and used laytime or time on demurrage will be counted as described in article 6.3.

6.1.2

If the vessel arrives at the Nyhamna Gas Plant before the Date Of Loading, the Operator shall not be considered to have received the Notice of Readiness tendered by the vessel until 06:01 hours on the first day of the date range within the Date Of Loading, and start of laytime shall not commence before 12:00 hours on that day. However, if the Operator actually commences loading prior to such time, laytime will begin to run from commencement of loading.

6.1.3

If the vessel arrives in port after 24:00 hours on the last day of the date range within the Date Of Loading, laytime shall begin to run upon commencement of loading.

6.2 Laytime allowances

CARGO SIZE (Metric Ton)	LAYTIME ALLOWANCE (HOURS)
Up to 60 000	30
60 000 - 80 000	36
80 000 and above	42

Cargo size in this article means the actual total loaded product as stated on the Bill Of Lading(s).

6.3 Adjustment of laytime allowances, used laytime and time on demurrage

6.3.1

Except as provided in articles 6.3.2 and 6.3.3, the total laytime allowed for loading shall be as stipulated in article 6.2.

6.3.2

Notwithstanding the above, failure to give 12 hours notice of vessel's ETA as required in article 3.5 will increase the laytime allowance by 12 hours.

6.3.3

Notwithstanding the above, and in order to avoid unacceptable surge pressures within the Nyhamna Gas Plant facilities, it may be necessary to restrict the loading rate to a vessel if such vessel's Effective Valve Closing Time is not compatible with the shore system. Should it be necessary to restrict the loading rate to a rate lower than the applicable "minimum loading rate" stated in the Harbour Regulations, then the additional time taken to load the Cargo will not count as used laytime or time on demurrage.

The additional time taken to load will be the difference between the loading time calculated at the aforementioned "minimum loading rate" - increased by 10

percent to allow for starting/topping off -, and the actual loading time - i.e. commenced loading to completed loading.

6.3.4

Notwithstanding the above, any delay due to the vessel's condition or breakdown or inability of the vessel's facilities to maintain its tanks in a suitable condition to load, or to load the Cargo within the time allowed, or when loading is delayed or suspended for vessel's purpose, shall not count as used laytime or time on demurrage.

6.3.5

All time consumed by the vessel in moving from the anchorage (anchor aweigh), or if the vessel is not at anchorage, from pilot on board to the loading berth (completed mooring), and in discharging ballast water - when not simultaneously with loading Cargo - shall not count as used laytime or time on demurrage except where the allowed laytime is exceeded prior to the commencement of the berthing and/or de-ballasting operations, in which event such operations will count as used laytime or time on demurrage.

6.3.6

All time spent alongside the loading berth for the purpose of preparing the vessel's Cargo tanks to a suitable condition for the reception of the Cargo to be loaded shall not count as used laytime or time on demurrage.

6.3.7

Where a vessel is delayed in berthing after Notice of Readiness has been correctly tendered in accordance with article 6.1.1, and such delay is caused by circumstances related to the vessel then such delay shall not count as used laytime or time on demurrage.

6.3.8

If requested by the Shipper, the vessel may be berthed more than once. The cost will be for Shipper's account.

6.4 Cessation of laytime or time on demurrage

Laytime or time on demurrage shall cease when the loading arms are disconnected.

6.5 Demurrage

In the event that the allowed laytime or time on demurrage, as described in article 6.3, is exceeded, Nyhamna Joint Venture shall pay demurrage per running hour, and pro rata for part thereof - for all such excess time, provided that laytime or time on demurrage shall not be counted for such time period(s) where the operations at the Nyhamna Gas Plant are delayed due to weather conditions.

The demurrage rate applicable for the Nyhamna Gas Plant shall be as per the actual demurrage rate of the charter party for the lifting in question, or, if the vessel is on time charter, and does not have an actual demurrage rate, the Average Freight Rate Assessment (AFRA) of Worldscale, applicable to the size of vessel as published by the London Tanker Brokers Panel and current on the date

of commencement of loading. If, however, demurrage is incurred as a result of fire, explosion, strike, lockout, stoppage or restraint of labour in or about the loading facilities, or of breakdown of machinery or equipment at the Nyhamna Gas Plant, the rate of demurrage mentioned above shall be reduced by one-half per running hour, or pro rata for part thereof, for demurrage thus incurred.

Nyhamna Joint Venture shall not be liable for any demurrage resulting from delay caused by strike, lockout, stoppage or restraint of labour for Master, officers and crew of the vessel or tugboats or pilots or boatmen.

If Shipper fail to conform to final nomination requirements in accordance with article 3.4.1 item E for any Part Cargo on a vessel, Nyhamna Joint Venture shall not be liable for any demurrage cost for all Part Cargoes on the vessel.

Nyhamna Joint Venture shall not be liable for any demurrage cost resulting from delay caused by field outages.

6.6 Demurrage claims

The demurrage rate shall be properly documented when the claim is filed with Nyhamna Joint Venture. Any such claim must be submitted within 90 Days after the Bill Of Lading date, on a format as requested by the Operator.

Demurrage claims shall be confirmed or rejected by the Operator within 2 Months from receipt of the claim.

The term of payment for demurrage claims shall be minimum 14 calendar days from receipt of invoice.

The costs for demurrage shall be included in the operational cost for Nyhamna Gas Plant.

6.7 Harbour fees and expenses

The Shipper is obligated to pay harbour fees and expenses as charged by the Operator.

6.8 Inspection of vessel

Before loading commences of any vessel at the Nyhamna Gas Plant, the Operator shall have the right to inspect such vessel to determine whether or not the vessel complies with the Harbour Regulations. Time for inspection shall not count as used laytime or time on demurrage.

The Operator shall have the right to reject such vessel if it determines that there is a safety risk involved in loading the vessel and/or unacceptable risk of contaminating Nyhamna Gas Plant facilities.

7 BERTHING PRIORITY

7.1 Arrival within set range

Vessels which have been nominated in accordance with article 3 and arrive within Date Of Loading will be berthed in order of arrival as evidenced by the time Notice of Readiness has been presented.

7.2 Arrival before set range

When the arrival of one or both of two accepted vessels occurs before commencement of Date Of Loading and when the order of arrival of the two vessels concerned is in reverse order to the order of their properly nominated dates, then if the prior berthing and loading of the vessel first to arrive would in the view of the Operator be detrimental to the loading of the second vessel, their berthing priorities will be established by applying the following rules:

- i) If one vessel arrives before its Date Of Loading and if the Date Of Loading of such vessel commences after the arrival of the second vessel which is within its Date Of Loading, then priority will be given to the second vessel.
- ii) If two vessels arrive before their respective Date Of Loading and if the required product is available for both vessels, then they will be berthed in order of arrival.
- iii) If two vessels arrive before their respective Date Of Loading and if the required product is not available for both vessels, then they will be berthed in the order of their respective Date Of Loading.

7.3 Arrival after Date Of Loading

When a vessel arrives after the expiry of its Date Of Loading, it will be berthed at the earliest possible time which will not be detrimental to the lifting programme at the Nyhamna Gas Plant.

7.4 The Operator's right

The Operator has the right to override the procedures in articles 7.1, 7.2 and 7.3, if necessary due to technical or operational reasons at the Nyhamna Gas Plant, keeping the Shipper advised if time permit.

8 DOCUMENTATION PROCEDURE

8.1 Introduction

The documents listed in article 8.2 will be prepared and distributed by the Operator provided that the Shipper has supplied sufficient information, including document instruction, in the system designated by the Operator, in order for the Operator to produce the applicable documents.

In the event that electronic transfer of data is impossible, then information may be given by telephone or e-mail to the person(s) indicated in article 3.7.2. Verbal information must be confirmed electronically at the first practical opportunity.

8.2 Standard set of documents

A standard set of documents will consist of:

- Bill Of Lading
- Cargo Certificates, which covers:
 - A) "Quantity Certificate"
 - B) "Quality Certificate - Analysis"
 - C) "Origin Certificate"
- "Statement of Facts"
- "Document Enclosure and Receipt Form"
- "Vessel's Sailing Advice"

If the Shipper requires additional documents this must be ordered through the Shipper's agent for the Shipper's cost.

Complete sets of documents will be distributed for every shipment of Condensate from the Nyhamna Gas Plant. A brief description of the documents follows:

The Bill Of Lading is a receipt for the Cargo(es), and contains a description of the product (gross and net quantity) loaded, i.e.:

- Cubic Meters at 15°C
- Metric Tons
- Metric tons in air
- Barrels

The Bill Of Lading figures will be based on metered mass or vessel loading report. (Ref. also article 3.8). An original Bill Of Lading is also a title of ownership of the Cargo(es) that are referred to therein. The Operator will issue one original Bill Of Lading. If additional original Bills Of Lading are required, then they will be issued in accordance with the Shipper's instructions.

The Bill(s) Of Lading will be dated when the total quantity of such Cargo has been loaded.

The "Quantity Certificate" is the basis for the Bill Of Lading quantity and states the total volume and weight loaded together with the product density and the basis of measurement used for custody transfer, i.e.;

- calculated based on shore quantity measurements, or
- calculated based on vessel's ullage report

Quantity measurements will be based on computerized loading control and automatic recording of metered quantities together with associated data adjusted

for registered documented quantity of Condensate lost between the measurement facilities at Nyhamna Gas Plant and the vessel's manifold ("Shore Metering").

If the Shore Metering system is unavailable the quantity shall be calculated based on the vessel's ullage report, and the volume of product loaded will be calculated by measurements taken on the vessel before and after loading according to API CHAPTER 17 SECTION 1 GUIDELINE FOR MARINE CARGO INSPECTION.

For the surveyor data or when using the vessel's ullage report the vessel's experience factor and Method 2 in Figure - PROCEDURE FOR CALCULATING VESSEL EXPERIENCE FACTOR in the API Guideline for Marine Inspection shall be used. The density to be determined by the laboratory at Nyhamna Gas Plant.

The "Quality Certificate - Analysis" will state the compositions and properties of the loaded product by analysis either;

- by flow proportional automatic sampling,

or in case of malfunction of the automatic sampling

- by spot samples taken from the jetty loading line at approx. 25 %, 50 % and 75 % of loading, and certificate figures are calculated as an average of the sample results.

The "Origin Certificate" describes the sources of the product and the document is prepared and signed by the Operator.

The "Statement of Facts" is compiled by the Operator from the arrival and departure log maintained at the jetty and in conjunction with the vessel's Master or the Master's representative.

The "Document Enclosure and Receipt Form" is a listing of the standard documents issued and the receivers of the respective standard documents.

The "Vessel's Sailing Advice" is a notice issued electronically listing the following details:

1. Cargo Reference Number
2. Vessel name
3. Time/date departure Nyhamna Gas Plant.
4. Product, and loaded temperature
5. Bill Of Lading quantities
6. Density
7. ETA (if known) at destination

This notice will be transmitted by the Operator, according to the document instruction, as soon as possible after the vessel has departed.

Other documents issued by the Shipper's agent may be included based on request from the Shipper.

8.3 Early departure

If requested by the Operator the Shipper shall instruct the vessel to leave the jetty prior to receiving the Cargo Documents as further described in the Harbour Regulations. Any additional cost related to issue or re-issue of Cargo Documents due to early departure shall be for the Shipper's cost, unless the Cargo Documents are delayed caused by the Operator's IT systems.

8.4 Other documents

Other documents required for a shipment of Condensate from the Nyhamna Gas Plant include the following:

- Notice of Readiness
- Ship/Shore safety checklist
- Cargo Data Sheet
- Agent's Statement of Facts
- Letter of Protest
- Ullage Reports

A brief description of the documents follows:

Notice of Readiness - This document is prepared by the Master of the vessel and states the time the vessel is ready to start loading.

Ship/Shore safety checklist - This document is signed by the Operator and the Master and states requirements for the vessel for being ready to start loading.

Cargo Data Sheet - This is a document stating details of the product.

Agent's Statement of Facts - This is a document issued by the Shipper's agent stating the arrival and departure log and will be signed by the Operator's representative, the Master and the Shipper's agent.

Letter of Protest - This is a document issued by the vessel and/or the Operator's representative stating any disagreement.

Ullage Reports - This is a document issued by the surveyor or vessel stating quantity loaded onboard the vessel.

8.5 Documentation related to Part Cargoes

Separate documentation is required for each Part Cargo.

9 QUANTITY CORRECTION PROCEDURE

9.1 Quantities and Vessel Experience Factor

"Bill Of Lading Quantity" shall mean the quantity in Cubic Meters at 15°C on the Bill Of Lading in accordance with the Quantity Certificate as described in article 8.2.

“Ship Figure After Loading” shall mean the total quantity in Cubic Meters at 15°C of liquid measured to be contained in the vessel’s cargo tanks after loading.

“Ships Figures Prior To Discharge” shall mean the total quantity in Cubic Meters at 15°C of liquid measured to be contained in the vessel’s cargo tanks. The quantity shall be determined at discharge port or near discharge port by an approved method and by a certified agency.

“Shore Figure At Discharge Port” shall mean the total quantity in Cubic Meters at 15°C of liquid delivered through the vessel’s discharge hose connection flanges and measured by certified transfer meters or other approved means of measurement.

“Vessel Experience Factor” shall mean the factor calculated as per API MPMS 17.9 or authentically standard EI HM 49.

9.2 Variance between quantities

In the event of a variance between the net Bill Of Lading Quantity and the closest of either:

- a) - gross Ship Figure After Loading divided by the Vessel Experience Factor
 - less quantity onboard the vessel before loading
 - less unsuspending water in the Condensate
 - less basic sediment and water
 - plus registered documented quantity of Condensate lost between the measurement facilities at Nyhamna Gas Plant and the vessel’s manifold not adjusted for in the Bill Of Lading Quantities equals Q I
- b) - gross Ship Figure Prior To Discharge divided by the Vessel Experience Factor
 - less quantity onboard the vessel before loading
 - less unsuspending water in the Condensate
 - less basic sediment and water
 - plus registered documented quantity of Condensate lost between Nyhamna Gas Plant and discharge ports, excluding evaporation equals Q II
- c) - gross Shore Figure At Discharge Port
 - plus remaining on board after discharge
 - less quantity onboard the vessel before loading
 - plus registered documented quantity of Condensate lost between the vessel’s manifold at discharge port and the shore measurement tanks and lines at the discharge port
 - less unsuspending water in the Condensate
 - less basic sediment and water equals QIII

being in excess of 0.30 per cent of the net Bill Of Lading Quantity the Shipper may file a claim to the Operator.

If either one or more of the QI, QII or QIII are higher than the net Bill Of Lading Quantity and one or more of the other(s) is lower the Shipper will not have a valid claim.

If the Shipper file a claim the Operator shall investigate the Nyhamna Gas Plant measurement facilities for failure or faulty operation during the loading. If the investigation provides evidence of error in the Nyhamna Gas Plant measurement facilities and the Shipper can provide evidence that the difference between net Bill Of Lading Quantity and the closest of QI, QII or QIII are in excess of 0.30 per cent of the Bill Of Lading Quantity the Operator shall adjust the Bill Of Lading Quantity to the quantity closest of the QI, QII or QIII.

In the event of a calculation error in the Bill Of Lading Quantity (also in the basic sediment and water and density) resulting in a variance in excess of +/- 0.02 per cent, the Shipper shall issue a claim to the Operator and the relevant Cargo documents shall be amended.

A claim must be issued to the Operator prior to 90 Days following the Bill Of Lading date. The Operator will not consider any claims received after this date.

Adjustment in accordance with this article 9 is subject to that the Shipper can provide full and complete supporting documentation including:

- the vessels ullage reports,
- Vessel Experience Factor details,
- water balance reports,
- outturn reports,
- sampling and analyses reports,
- independent inspector's reports and
- voyage details.

All supporting documentation must certify that the information is obtained using approved equipment and the Shipper must demonstrate that the equipment used was suitably maintained and functioning correctly during the discharge of the Cargo.

The Norwegian Petroleum Directorate shall be notified and is to accept the quantity adjustment prior to any adjustment of the Bill Of Lading Quantity by the Operator. If no comments from the Norwegian Petroleum Directorate is received within 3 weeks from notification the adjustment is regarded accepted by the authority.

10 QUALITY COMPENSATION PROCEDURE

10.1 Introduction

Notwithstanding Terms and Conditions Article 10.1 and 10.3, in case the Condensate delivered hereunder does not meet the Specifications as described in the Operations Manual, article 7.5, the Shipper may claim compensation in accordance with the provisions of this article 10.

10.2 Documentation and information

All quality compensations shall be subject to verified product quality specifications as documented in the Quality Certificate provided by an authorised laboratory.

If a result is disputed, the Shipper may initialise a re-evaluation of the sample at a laboratory. Such re-evaluation will be at the sole costs and expenses of the Shipper.

Product quality compensation shall not be subject to test figures arising from the discharging of the vessel in question, nor from any other terminal or external body nominated by the Shipper or by the receivers.

10.3 Compensation and claims handling

Compensation for Condensate according to this procedure shall be limited to direct losses incurred by the Shipper and shall not exceed a total amount of 1 million USD.

Claims, including full documentation, shall be submitted within 90 Days after the Bill of Lading date or otherwise be regarded as a non-valid claim.

The Shipper shall verify its actual losses from price discounts and / or additional freight costs prior to receiving compensation.

The Shipper shall verify that attempts have been made to minimise the losses.

10.4 Payment and accounting

Compensation shall be confirmed or rejected by the Operator within 1 Month from receipt of claim.

The costs for quality compensation shall be included in the operational cost for Nyhamna Gas Plant.

APPENDIX D

TO

**TERMS AND CONDITIONS FOR
PROCESSING OF GAS AT NYHAMNA GAS PLANT**

**PRINCIPLES FOR OPERATOR'S PUBLICATION OF
OPERATIONAL INFORMATION**

1 PLANNED AND UNPLANNED EVENTS

For unplanned and planned events affecting fields and/or the Nyhamna Gas Plant, outages that may affect the daily capacity above 5 MSm³ will be published. The following information will be provided:

Event ID / Asset affected / Type of Unavailability / Revision / Time of Publication / Event Start / Event stop / Technical capacity / Available capacity / Unavailable capacity / Type of event / Reason for the unavailability / Remarks

The term “Technical capacity” in this respect refers to the maximum capacity/availability that the affected asset can flow for a long period of operation in normal conditions. The term “Available capacity” refers to the remaining available daily capacity/availability of the affected asset.

The term “Unavailable capacity” refers to the unavailable capacity/availability of the affected asset.

Information of planned events (maintenance) will be published simultaneously with information provided to the shippers of such planned maintenance. Available capacity for planned maintenance may be uncertain depending on actual operational conditions. These events will be commented with “uncertain capacity”, and may have an uncertainty of up to ± 5 MSm³/d.

If an unplanned event has a duration above one day, an uncertainty of up to ± 2 MSm³/d may occur in the reporting due to variation in operational conditions. Information of unplanned events will be performed as soon as practically possible, but not later than one hour after the shippers have been informed about the curtailment.

2 PUBLICATION

The above information will be published by the Operator on umm.gassco.no