

**TERMS AND CONDITIONS**

**FOR**

**TRANSPORTATION**

**OF GAS**

**IN**

**UTSIRA HIGH GAS PIPELINE**

**Valid from 1 October 2024**

## TABLE OF CONTENTS

<b>1</b>	<b>APPLICABILITY, RELATIONSHIP, DEFINITIONS, AND DOCUMENTS</b>	<b>4</b>
1.1	Applicability .....	4
1.2	Relationship .....	4
1.3	Definitions .....	4
1.4	Appendices .....	10
1.5	Hierarchy .....	10
<b>2</b>	<b>TRANSPORTATION COMMITMENT AND OPERATION</b>	<b>10</b>
2.1	Shipper's obligation to provide Linefill .....	10
2.2	Transportation Commitment .....	10
2.3	Daily Transportation Commitment .....	11
2.4	Operation .....	11
2.5	Planned maintenance .....	11
2.6	Safety, system integrity and/or environmental protection .....	11
2.7	Installations, connections, modifications, tie-in .....	12
2.8	Priorities .....	12
<b>3</b>	<b>DELIVERY RIGHT AND OBLIGATION AND OFFTAKE</b>	<b>12</b>
3.1	Delivery Right and Obligation .....	12
3.2	Forecasts .....	12
3.3	Nomination .....	12
3.4	Offtake .....	13
3.5	Changes to Booked Capacity .....	13
3.6	Island Mode .....	13
<b>4</b>	<b>OPERATING AND QUALITY REQUIREMENTS</b>	<b>13</b>
4.1	Requirements at the Entry Point(s) .....	13
4.2	Right to refuse delivery .....	13
4.3	Gas not complying with requirements at the Entry Point .....	13
4.4	Right to take operational actions .....	14
4.5	Requirements at the Exit Point(s) .....	14
4.6	Right to refuse redelivery .....	14
<b>5</b>	<b>TARIFF</b>	<b>14</b>
5.1	Transportation Tariffs .....	14
5.2	Capacity Fee Obligation .....	14
5.3	Other costs .....	15
5.4	Removal and abandonment costs .....	15
<b>6</b>	<b>MONTHLY INVOICE AND PAYMENT</b>	<b>15</b>
6.1	Monthly statement and invoice .....	15
6.2	Payment .....	15
6.3	Adjustment of preliminary invoice .....	16
6.4	Interest on amount due .....	16
6.5	Suspension and termination .....	16
6.6	Financial qualification .....	17
6.7	Change in financial circumstances .....	17
6.8	Audit .....	17
6.9	Rounding .....	18

<b>7</b>	<b>MEASUREMENT, TEST AND ANALYSES .....</b>	<b>18</b>
7.1	General.....	18
7.2	Measurement audit.....	18
<b>8</b>	<b>DETERMINATION OF QUANTITIES.....</b>	<b>18</b>
8.1	Allocation of Gas .....	18
8.2	Replacement Gas .....	18
<b>9</b>	<b>GUARANTEE.....</b>	<b>19</b>
9.1	Shipper's guarantee.....	19
9.2	Utsira High Gas Pipeline's guarantee .....	19
<b>10</b>	<b>LIABILITY AND INSURANCE.....</b>	<b>19</b>
10.1	Risk of loss of Gas .....	19
10.2	Shipper's indemnification right.....	20
10.3	Utsira High Gas Pipeline's and the Operator's indemnification right .....	20
10.4	Not in use .....	21
10.5	Liability for Off-spec Gas .....	21
10.6	Escape of Gas .....	21
10.7	Insurance .....	22
10.8	Utsira High Gas Pipeline's liability .....	22
10.9	Shippers' shared liability .....	23
<b>11</b>	<b>FORCE MAJEURE.....</b>	<b>23</b>
11.1	Force Majeure .....	23
11.2	Relief due to Force Majeure .....	23
11.3	Notification and Remedies .....	23
11.4	Long term Force Majeure.....	24
<b>12</b>	<b>MISCELLANEOUS .....</b>	<b>24</b>
12.1	Notices .....	24
12.2	Notice in case of restructuring .....	24
12.3	Confidentiality.....	24
12.4	Telecommunications and data transmission.....	26
12.5	Time reference .....	26
12.6	Amendments to the Terms and Conditions including the Appendices.....	26
<b>13</b>	<b>TERM OF AGREEMENT .....</b>	<b>26</b>
13.1	Termination of the Transportation Agreement .....	26
13.2	Survival of Termination .....	26
<b>14</b>	<b>ASSIGNMENT .....</b>	<b>27</b>
<b>15</b>	<b>APPLICABLE LAW AND ARBITRATION .....</b>	<b>27</b>

# 1 APPLICABILITY, RELATIONSHIP, DEFINITIONS, AND DOCUMENTS

## 1.1 Applicability

The objective of these Terms and Conditions is to regulate the rights and obligations of the Parties with regard to the provision and use of the Transportation Services.

The Terms and Conditions apply to all of the Shipper's Bookings in the Transportation System and any Transportation Services provided in respect of Shipper's Gas.

The Shipper's Bookings and the Terms and Conditions, the Appendices and the relevant parts of the Shipper Manual constitute the Transportation Agreement.

The Parties' rights and obligations pursuant to these Terms and Conditions shall be interpreted and construed to comply with, and be limited by, applicable statutory laws and regulations pertaining to the Transportation System, hereunder "*Forskrift 27. juni 1997 nr. 653 til lov om petroleumsvirksomhet kapittel 9*" and *Tarifforskriften* as amended from time to time.

## 1.2 Relationship

The Transportation Agreement is entered into between the Shipper and Utsira High Gas Pipeline.

The Operator is Utsira High Gas Pipeline's representative under the Transportation Agreement. The Operator will conduct all operations in the Transportation System and, on behalf of Utsira High Gas Pipeline, provide the Transportation Services and execute all Utsira High Gas Pipeline's rights and obligations under the Transportation Agreement.

## 1.3 Definitions

In the Terms and Conditions and in the Appendices the following terms shall have the meaning ascribed to them below:

1. "Affiliated Company" shall in relation to a Participant or the Shipper, mean:
  - (i) any enterprise which directly or indirectly holds more than 50 per cent of the share capital or the votes, or in any other way directly or indirectly exercises a controlling interest, in such Participant or Shipper, or
  - (ii) any enterprise in which such Participant or Shipper directly or indirectly holds more than 50 per cent of the share capital or the votes, or in any other way directly or indirectly exercises a controlling interest, or

- (iii) any enterprise of which more than 50 per cent of share capital or votes are held directly or indirectly, or which in any other way directly or indirectly is controlled, by one or more enterprise(s) which hold directly or indirectly more than 50 percent of the share capital or the votes, or in any other way exercises directly or indirectly a controlling interest, in such Participant or Shipper.
- 2. "Agent" shall mean any person who has been appointed by the Shipper and who acts on behalf of the Shipper with regard to that Shipper's rights and obligations in connection with the Transportation Agreement.
- 3. "Appendix" or "Appendices" shall mean the documents listed in Article 1.4.
- 4. "Article" shall mean an article of the Terms and Conditions.
- 5. "Bilateral Transaction" shall mean transactions related to change of entitlement to Gas upstream of or at any Entry Point, within the Transportation System and/or at any Exit Point, which will affect deliveries or redeliveries of Shipper's Gas.
- 6. "Booked Capacity" shall mean the Booked Entry Capacity, Booked Exit Capacity and / or Interruptible Booking, as the case may be, according to the Shipper's Bookings.
- 7. "Booked Entry Capacity" shall mean the sum of the capacity rights expressed in Sm<sup>3</sup> per Day for which the Shipper holds Bookings at the designated Entry Point(s). Booked Entry Capacity shall mean the Booked Exit Capacity.
- 8. "Booked Exit Capacity" shall mean the sum of the capacity rights expressed in Sm<sup>3</sup> per Day, for which the Shipper holds Bookings at the designated Exit Point(s).
- 9. "Booking" shall mean a Transportation Request made by the Shipper and accepted by the Operator in accordance with the Booking Manual.
- 10. "Booking Manual" shall mean the detailed procedures established by the Operator, at any time applicable, for inter alia the reservation, allocation, transfer, release and adjustment of capacity in the Transportation System.
- 11. "Booking Period" shall mean the period that consists of each of the Days for which the Shipper has Booked Capacity.
- 12. "Business Day" shall mean any calendar day that is neither a Saturday, a Sunday nor public holiday in Norway.

13. "Capacity Fee Obligation" shall have the meaning set forth in Article 5.2 first paragraph.
14. "Company Agreement" shall mean the "Company Agreement for Utilisation of Gassco Systems" between the Operator and the Shipper.
15. "Confidential Information" shall mean any information obtained by the Shipper from the Operator or by the Operator from the Shipper in connection with the Transportation Agreement, which is not available in the public domain.
16. "Contractor" shall mean any person who has entered into an agreement with a Party for the supply of materials and/or services in connection with the Transportation Agreement and who acts in its own name and on its own behalf.
17. "Cumulative Reserved Capacity" shall mean the Booked Capacity less capacity initially reserved as Interruptible Booking at the relevant booking point. If Daily Nominations for any period is higher than Booked Capacity the highest quantity shall be included in Cumulative Reserved Capacity.
18. "Daily Nominations" shall have the meaning set forth in Article 3.3 first paragraph.
19. "Daily Transportation Commitment" shall have the meaning set forth in Article 2.3.
20. "Day" shall mean the period beginning at 06:00 hours on a day and ending at 06:00 hours on the following day. However, for transportation of gas to Exit Points in UK, Day shall mean the period beginning at 07:00 hours on a day and ending at 07:00 hours on the following day. The date of any Day shall be the date of its beginning as herein defined.
21. "Degree Celsius" or "°C" shall be determined as the particular interval between any temperature in Kelvin minus the temperature of 273.15 Kelvin.
22. "Desk Quotation" shall mean the broker proposal obtained by the Operator each year for insurance of the Transportation System, including Third Party liability insurance.
23. "Entry Point" shall mean the point at which the Shipper will deliver Gas to Utsira High Gas Pipeline for Transportation Services. The Entry Points are further defined in the Transportation System Description.
24. "Exit Point" shall mean the point at which Utsira High Gas Pipeline will redeliver Gas to the Shipper. The Exit Points are further defined in the Transportation System Description.

25. "Financially Qualified Company" shall mean an undertaking that has passed and continues to pass the credit rating conditions given in the Qualification of Shipper Procedure.
26. "Force Majeure" shall have the meaning set forth in Article 11.1.
27. "Gas" shall mean any Rich Gas.
28. "Gassco Booking System" shall mean the internet based solution for inter alia booking of capacity and services in the Transportation System.
29. "Interruptible Booking" shall mean a Transportation Request in respect of Interruptible Capacity made by the Shipper and accepted by the Operator in accordance with the Booking Manual.
30. "Interruptible Capacity" shall mean capacity that may be interrupted by the Operator at any time in order to fulfil shippers' nominations under a firm capacity reservation.
31. "Island mode" shall have the meaning set forth in Article 3.6.
32. "Linefill" shall have the meaning set forth in Article 2.1.
33. "Maintenance Period" shall have the meaning set forth in Article 2.5.
34. "Ministry" shall mean the Norwegian Ministry of Energy or its successor.
35. "Month" shall mean the period beginning on the first Day of any calendar month and ending on the first Day of the succeeding calendar month.
36. "Off-spec Gas" shall mean Gas that does not meet the Specifications at the relevant Entry Point and / or Exit Point.
37. "Operations Manual" shall mean the detailed requirements for operation of the Transportation System as described in Appendix A.
38. "Operator" shall mean Gassco AS or its successor as determined by the Ministry.
39. "Participant" shall mean any of the owners of Utsira High Gas Pipeline at any time.
40. "Party" shall mean either Utsira High Gas Pipeline or the Shipper, and "Parties" shall mean Utsira High Gas Pipeline and the Shipper.
41. "Qualification of Shipper Procedure" shall mean the at any time applicable part of the Booking Manual regarding the credit rating

requirements applicable for undertakings that want to transport Gas in the Transportation System.

42. "Reasonable and Prudent" when used to describe the standard of care to be exercised by a Party or the Operator in performing its obligations hereunder shall mean that degree of diligence, prudence and foresight reasonably and ordinarily exercised by experienced companies engaged in the same line of business under the same or similar circumstances and conditions having due consideration to the interests of the other Party.
43. "Replacement Gas" shall mean Gas for replacement of minor losses under normal operation of the Transportation System.
44. "Rich Gas" shall mean any hydrocarbon or mixture of hydrocarbons and non-combustible gases in the gaseous state, which is extracted from the reservoirs in a particular field in its natural state or together with the liquid hydrocarbons, processed and exported in dense phase in order to meet the Specification for delivery into the Transportation System.
45. "Shipper" shall mean the company designated as such in the Booking and thereby being a Party to the Transportation Agreement. When the term "shipper" or "shippers" is used it shall mean the parties designated as such in some or all bookings in the Transportation System and thereby parties to some or all transportation agreements with Utsira High Gas Pipeline. The term shipper/shippers shall also include the Shipper.
46. "Shipper Manual" shall mean detailed procedure established by the Operator, at any time applicable, for inter alia regulating the communication between the Shipper and the Operator.
47. "Shipper's Bookings" shall mean the sum of the Bookings the Shipper holds at any time.
48. "Shipper's Facilities" shall mean;
  - a) any platforms, pipelines, wells, plant, machinery or any other equipment or facilities (whether or not owned or operated by the Shipper) upstream of the Entry Point(s) used from time to time to produce, receive, process, compress, store, treat and transport Gas to be delivered at the Entry Point(s) under the Transportation Agreement; and/or
  - b) any pipelines, plant, machinery, meters, valves or other equipment or facilities (whether or not owned or operated by the Shipper) at or immediately downstream of the Exit Point(s) required for the Shipper to take redelivery of Gas at the Exit Point(s).



49. "Sm<sup>3</sup>" (standard cubic metre) of Gas shall mean the quantity of Gas at 15 Degrees Celsius and at an absolute pressure of 1.01325 bar and when free of water vapour occupies the volume of 1 cubic metre.
50. "Specifications" shall mean the operating conditions and quality specifications given in the Operations Manual articles 4.1 and 4.2.
51. "Subcontractor" shall mean any person who has entered into an agreement with a Contractor for the supply of materials and/or services in connection with the Terms and Conditions and who acts in its own name and on its own behalf.
52. "Tariff(s)" shall mean the at any time applicable fees payable for the Transportation Services.
53. "Tarifforskriften" shall mean "Forskrift om fastsettelse av tariffer m.v. for bestemte innretninger av 20. desember 2002" as amended from time to time.
54. "Terms and Conditions" shall mean the rules herein setting out the Parties rights and obligations regarding the services in the Transportation System.
55. "Third Party" shall mean any party other than the Operator and the Parties.
56. "Transportation Agreement" shall have the meaning set forth in Article 1.1 third paragraph.
57. "Transportation Commitment" shall have the meaning set forth in Article 2.2.
58. "Transportation Request" shall mean a request for Transportation Services submitted to the Operator in accordance with the Booking Manual.
59. "Transportation Services" shall mean all or part of the services offered to the Shipper by Utsira High Gas Pipeline in the Transportation System.
60. "Transportation System" shall mean the facilities at any time in place to receive Shipper's Gas at the Entry Point(s), transport and redeliver the Gas at the Exit Point(s), in accordance with the Transportation Agreement, as detailed in Transportation System Description. The Transportation System is determined as Area L in Tarifforskriften.
61. "Transportation System Description" shall mean the detailed description of the Transportation System described in Appendix B.
62. "Utsira High Gas Pipeline" shall mean the owner of the Transportation System.

63. "Year" shall mean a period of 12 Months commencing at 06:00 hours on the 1 October of any calendar year and ending at 06:00 hours on the 1 October in the succeeding calendar year, and the Year shall be named after the year in which the Year commences.

#### **1.4 Appendices**

The following Appendices are attached to the Terms and Conditions:

- Appendix A: Operations Manual  
Appendix B: Transportation System Description

#### **1.5 Hierarchy**

Unless otherwise explicitly stated or clearly appears from the context, in the event of any conflict between the provisions in the various parts of the Transportation Agreement, they shall be given priority in the following order:

- 1) The Terms and Conditions
- 2) The Appendices
- 3) The Shipper Manual

## **2 TRANSPORTATION COMMITMENT AND OPERATION**

### **2.1 Shipper's obligation to provide Linefill**

In order for Utsira High Gas Pipeline to take on the Transportation Commitment, the Shipper is obliged to provide Utsira High Gas Pipeline with its share of the minimum quantity of Gas necessary to pressurise the Transportation System ("Linefill").

The basis for and any change or recalculation of the ownership of the Linefill shall be in accordance with the procedure set forth in the Shipper Manual.

### **2.2 Transportation Commitment**

Utsira High Gas Pipeline undertakes to receive quantities of Gas up to the Booked Entry Capacity from the Shipper at the Entry Point(s) and to transport and redeliver Gas to the Shipper at each Exit Point(s) up to the Booked Exit Capacity throughout the Booking Period (the "Transportation Commitment").

Utsira High Gas Pipeline does not undertake any Transportation Commitment in respect of Interruptible Capacity.

### **2.3 Daily Transportation Commitment**

Utsira High Gas Pipeline's Daily Transportation Commitment shall unless otherwise specified in the Transportation Agreement be equal to the quantities nominated by the Shipper in accordance with Article 3.3.

If the Shipper after the deadline for the Daily Nominations makes a re-nomination, the Operator shall use reasonable endeavours to accept the re-nomination. If the Operator accepts the re-nomination, the Transportation Commitment shall be equal to the re-nominated quantities.

### **2.4 Operation**

Throughout the Booking Period Utsira High Gas Pipeline shall operate, maintain and repair the Transportation System in a Reasonable and Prudent manner.

### **2.5 Planned maintenance**

Utsira High Gas Pipeline shall each Year for reasons of planned maintenance of the Transportation System have the right to reduce (if necessary down to 0) the Transportation Services (the "Maintenance Period").

The Maintenance Period shall preferably be within the Months of April through September. The Maintenance Period shall be determined by the Operator in accordance with the Operations Manual article 2.5. The Operator shall use all reasonable efforts to minimise the duration of the Maintenance Period and to coordinate the Maintenance Period in order to minimise the disruption to the Transportation Services.

The Maintenance Period shall be limited to 20 consecutive Days.

### **2.6 Safety, system integrity and/or environmental protection**

Utsira High Gas Pipeline may for reasons of safety, system integrity and/or environmental protection curtail or shut-off the Shipper's delivery of Gas to the Transportation System to perform repairs and/or extraordinary maintenance of the Transportation System, provided that said actions cannot reasonably be deferred to a subsequent Maintenance Period.

The curtailment or shut-off period will be determined by the Operator acting in a Reasonable and Prudent manner. The Operator shall promptly notify the Shipper of the reason for such action, the extent of curtailment or shut-off and the possible duration of such curtailment or shut-off. To the extent time is available, the Operator shall coordinate the curtailment or shut-off with the Shipper in order to minimise the effect of such curtailment or shut-off.

## **2.7 Installations, connections, modifications, tie-in**

Utsira High Gas Pipeline may curtail or shut-off the Shipper's delivery of Gas to the Transportation System if necessary for reasons of any operations, inter alia installations, connections, modifications, tie-in operations, disconnections and removals which cannot be reasonably deferred to a Maintenance Period.

Utsira High Gas Pipeline's right to curtail or shut-off the Shipper's delivery of Gas shall for each Year be limited to 20 Days, provided, however, that the Operator shall use all reasonable efforts to minimise the duration of any such curtailment or shut-off.

The Operator shall as soon as possible and not less than 120 days prior to commencement notify the Shipper of the timing and extent of any such operations. In the planning and scheduling of the operations the Operator shall seek to minimise necessary shut-off periods and to cause least possible disruptions to the Transportation Services including minimising the negative effects for the Shipper.

## **2.8 Priorities**

In case of reduced capacity in the Transportation System the Operator will reallocate capacity to the shippers according to the priority rules set out in the Operations Manual article 3.3.

# **3 DELIVERY RIGHT AND OBLIGATION AND OFFTAKE**

## **3.1 Delivery Right and Obligation**

The Shipper has, throughout the Booking Period, the right and obligation to deliver at the Entry Point(s), the quantities of Gas corresponding to its Daily Nominations.

## **3.2 Forecasts**

The Shipper shall provide forecasts of its deliveries of Gas at each Entry Point. The content of the forecasts shall be in accordance with the requirements of the Operations Manual article 2.1.

## **3.3 Nomination**

The Shipper shall for each Day make nominations of quantities of Gas to be delivered at each of the Entry Points and redelivered at each of the Exit Points (the "Daily Nominations"). The Daily Nominations shall be made, and adjusted in case of re-nominations, in accordance with the Operations Manual article 2.3.

The Daily Nominations shall not exceed the Shipper's Booked Capacity for the Day in question.

The sum of the Daily Nominations for the Entry Point(s) must always be equal to the sum of the Daily Nominations for the Exit Point(s), adjusted for Bilateral Transaction and Linefill.

### **3.4 Offtake**

The Shipper shall on each Day be obliged to accept redelivery at the Exit Point(s) quantities of Gas equal to the Daily Nominations.

### **3.5 Changes to Booked Capacity**

Any changes to the Shipper's Booked Capacity shall be made in accordance with the Booking Manual.

### **3.6 Island Mode**

If the Operator receives notification or has reason to believe that Shipper is isolated from normal communication lines affecting the ability to perform dispatching ("Island mode"), the Operator shall be authorised, as the Operator deems appropriate in its sole opinion, to proceed in accordance with the Island mode procedure as described in the Shipper Manual. Any costs, claims (including third party claims), losses and other consequences related to the Operator's actions or inactions under Island mode shall be for the Shipper's risk and account.

## **4 OPERATING AND QUALITY REQUIREMENTS**

### **4.1 Requirements at the Entry Point(s)**

The Shipper shall at the Entry Point(s) deliver Gas that meets the Specifications.

Notwithstanding the above, if the Shipper's Gas is delivered together with other shippers' Gas at the Entry Point, the Shipper's Gas shall be deemed to meet the Specifications if the commingled stream of all shippers' Gas delivered at the Entry Point, meets the Specifications at such Entry Point.

### **4.2 Right to refuse delivery**

The Operator may at all times refuse to accept the Shipper's Off-spec Gas or the Shipper's Gas if delivered in an Off-spec Gas commingled stream. The Shipper shall in such case immediately stop any delivery of Gas.

### **4.3 Gas not complying with requirements at the Entry Point**

Notwithstanding Articles 4.1 and 4.2, Utsira High Gas Pipeline shall use reasonable endeavour to accept Off-spec Gas or the Shipper's Gas if delivered in an Off-spec Gas commingled stream, provided that, in the reasonable opinion of the Operator, such Off-spec Gas would neither be detrimental to the operation of the Transportation System nor affect Utsira High Gas Pipeline's ability to redeliver Gas to all shippers in accordance with Article 4.5.

#### **4.4 Right to take operational actions**

If the Shipper has delivered Off-spec Gas or has delivered Gas in an Off-spec Gas commingled stream, the Operator shall have the right to take necessary operational actions to dispose of the Shipper's Gas at a convenient location or, if possible and subject to the respective field operator's prior approval, backflow the Gas.

#### **4.5 Requirements at the Exit Point(s)**

Utsira High Gas Pipeline shall redeliver at the Exit Point(s) Gas that meets the Specifications.

#### **4.6 Right to refuse redelivery**

The Shipper may refuse to accept redelivery of its Gas provided that the transportation system downstream of the Exit Point, based on the quality provisions of that system, refuses to take said Gas. In such case the Operator shall in agreement with the Shipper and at the Shipper's cost take the necessary operational action to dispose of such Gas.

However, if Article 4.5 is not fulfilled by Utsira High Gas Pipeline, then the Operator shall, notwithstanding Articles 10.2 and 10.3, at Utsira High Gas Pipeline's cost take the necessary operational action to dispose of such Gas.

## **5 TARIFF**

### **5.1 Transportation Tariffs**

The Tariffs for the Transportation Services shall be calculated in accordance with Tarifforskriften.

The Tariffs shall be published on [www.gassco.no](http://www.gassco.no).

### **5.2 Capacity Fee Obligation**

Throughout the Booking Period, the Shipper is obliged to pay the Tariffs for a quantity of Gas corresponding to the Booked Entry Capacity and/or the Booked Exit Capacity (the "Capacity Fee Obligation"), or the Daily Nominations, whichever is the higher, for the applicable Entry and Exit Points.

The Capacity Fee Obligation shall be suspended during any period and to the extent Utsira High Gas Pipeline does not provide Transportation Services including, but not limited to;

- a) events described in Articles 2.5, 2.6 or 2.7 or Force Majeure (according to Article 11) affecting Utsira High Gas Pipeline preventing the Shipper's Gas from being received, handled, transported or redelivered by Utsira High Gas Pipeline,

- b) periods when Utsira High Gas Pipeline does not redeliver Gas in accordance with Article 4.5 and the Shipper has the right according to Article 4.6 second paragraph to refuse to take redelivery.

### **5.3 Other costs**

The Shipper shall reimburse the Operator or Utsira High Gas Pipeline, as applicable, relevant taxes and/or fees levied on the Shipper's Gas that the Operator or Utsira High Gas Pipeline pays on behalf of the Shipper.

### **5.4 Removal and abandonment costs**

Costs for removal and/or abandonment according to legal requirement, of all or any part of the Transportation System, and any costs including but not limited to clean up costs associated therewith, shall be paid by the Shipper.

The Shipper's share of removal and abandonment costs related to Utsira High Gas Pipeline is based on the Shipper's Cumulative Reserved Capacity at the Exit Point(s) in proportion to all shippers' Cumulative Reserved Capacity at the Exit Point(s).

## **6 MONTHLY INVOICE AND PAYMENT**

### **6.1 Monthly statement and invoice**

On or before the 7th Business Day of each Month, the Operator shall submit an invoice to the Shipper showing the total amount payable by the Shipper to Utsira High Gas Pipeline for the preceding Month. The invoice shall inter alia specify;

- a) the Booked Capacity,
- b) the Tariffs applicable,
- c) deductions, if any, in Capacity Fee Obligation according to Article 5.2 second paragraph,
- d) any other information that influence the amount payable.

The Tariffs and the total amount payable shall be in the official Norwegian currency.

If all data is not available, Utsira High Gas Pipeline may issue a preliminary invoice.

### **6.2 Payment**

The amount payable by the Shipper shall be paid and credited to bank accounts designated by Utsira High Gas Pipeline on the 20th day of the

Month in which the invoice referred to in Article 6.1 was submitted or not later than 10 days after receipt of said invoice, whichever date comes later.

The invoiced amount shall except in the case of manifest errors be paid without any deductions whether or not any part of or the entire amount is disputed.

### **6.3 Adjustment of preliminary invoice**

If any invoice was based on preliminary figures Utsira High Gas Pipeline shall, as soon as possible, render to the Shipper a new invoice showing the appropriate adjustments to the preliminary invoice in the same manner as described in Article 6.1. The amount resulting from the adjustment, including interest, shall if payable by the Shipper, be paid not later than 20 days after the date of receipt of said new invoice. The amount resulting from the adjustment, including interest, shall if payable by Utsira High Gas Pipeline, be paid not later than 20 days after the date of submission of said new invoice.

Interest on the amount of adjustment shall be calculated at an annual rate equal to 3 months NIBOR as published by the Dagens Næringsliv, Oslo, on the first Business Day in the Month of issuance of the new invoice.

Interest shall be paid for the period starting from and including the due date of the relevant preliminary invoice and ending on but excluding the value date of payment of said adjustment.

### **6.4 Interest on amount due**

Should any Party fail to make any payment due hereunder at the time and in the manner provided for herein, the amount due shall bear interest for the period starting on and including the due date for payment and ending on, but excluding the value date for payment, calculated in accordance with the Law relating to Interest on Overdue Payments etc., of 17 December 1976 no. 100 ("Forsinkelsesrenteloven").

### **6.5 Suspension and termination**

If the Shipper's failure to pay any sum due continues for 5 Business Days or more following the due date for payment of such amount, then at any time thereafter Utsira High Gas Pipeline may by 5 Business Days' notice to the Shipper, suspend the Transportation Services until the amount due has been paid by the Shipper (or by a guarantor on behalf of the Shipper).

The suspension shall not relieve the Shipper from the Capacity Fee Obligation.

If the Shipper's default continues for 60 days or more following the due date for payment, then at any time thereafter Utsira High Gas Pipeline may by notice to the Shipper, terminate the Transportation Agreement from the date specified in such notice.



## 6.6 Financial qualification

If the Shipper is not a Financially Qualified Company, the Shipper shall provide such guarantee as required by the Operator without undue delay.

Until a required guarantee is provided, the Shipper shall be obliged to make its Tariff payments in advance. The Shipper shall be required to pre-pay an amount equal to the estimated sum of the Tariffs applicable to the Shipper's Booked Capacity for the current and the following 2 Months, and then by pre-payment on the 20th day of each Month maintain a pre-paid amount equal to the estimated sum of the Tariffs applicable to the Shipper's Booked Capacity for the current and the following 2 Months.

If the Shipper fails to provide a guarantee within a reasonable deadline determined by the Operator or make any required pre-payment, Utsira High Gas Pipeline shall have the right to suspend the Transportation Services or terminate the Transportation Agreement immediately, and Article 6.5 second paragraph shall apply.

## 6.7 Change in financial circumstances

The Shipper shall notify the Operator immediately if at any time

- a) the Shipper initiates a merger, dissolution, liquidation, winding up, reduction of share capital or a similar process, or
- b) there is a material deterioration in the financial resources of the Shipper,

that is likely to have an adverse effect on the Shipper's ability to fulfil its obligations under the Transportation Agreement and/or in case of a credit rating downgrade of the Shipper or its guarantor.

## 6.8 Audit

The Shipper shall, upon 30 days' notice to the Operator, have the right to examine and audit the Operator's books and records for the years in which the Shipper's Gas was transported in the Transportation System and which are relevant to the allocation of Shipper's Gas and the Tariffs charged to the Shipper.

The audits shall be conducted within the 24 months period following the end of the year in question. If the audit reveals any inaccuracy in any invoice rendered, the necessary adjustments to such invoice and payments including interest in accordance with Article 6.3, shall be made promptly. No adjustment for any invoice or payments shall be made with respect to any claims filed after the expiration of the 24 months.

The Shipper shall conduct the audits at reasonable hours and in a manner, which will result in a minimum of inconvenience to Utsira High

Gas Pipeline and the Operator. The Shipper shall cover its own expenses for the audit.

The Shipper's right to audit shall not include Confidential Information regarding other shippers. If examination of such Confidential Information is necessary, an independent auditor shall perform such part of the audit. The independent auditor shall only confirm whether the Operator's calculations are correct and shall not reveal any Confidential Information to the Shipper.

Subject to the preceding paragraph, the Shipper shall endeavour to conduct the audit during the same period as other shippers.

### **6.9 Rounding**

All calculations in the Transportation Agreement shall be made to 7 places of decimals. A figure of 5 or more in the 8th decimal place shall cause a rounding up of the 7th decimal place.

## **7 MEASUREMENT, TEST AND ANALYSES**

### **7.1 General**

All measurement, testing, on-line analysis and sampling shall be performed in accordance with the requirements in the Operations Manual article 5. Any necessary changes to agreed measurement, testing, on-line analysis and sampling shall be discussed with the Shipper before implemented.

### **7.2 Measurement audit**

The Parties may conduct such audits as provided for in the Operations Manual article 5 at each other's facilities. Such audits shall be coordinated and performed during the normal office hours in effect at the facilities at the time of the audit and in a manner which shall result in a minimum of inconvenience. The Shipper shall give a notice of at least 90 Days, specifying involved facilities, scope and options for preferred audit periods.

## **8 DETERMINATION OF QUANTITIES**

### **8.1 Allocation of Gas**

The allocation to the Shipper of quantities of Gas hereunder shall be determined in accordance with the Operations Manual article 6.

### **8.2 Replacement Gas**

Replacement Gas shall be supplied by the Shipper in kind based on the Shipper's Daily Nominations.

Deliveries of Replacement Gas shall be made in accordance with the Operations Manual article 6.

## **9 GUARANTEE**

### **9.1 Shipper's guarantee**

The Shipper guarantees that it at the time of delivery and continuing up and until the time of redelivery has the right to dispose of all Gas delivered by it to Utsira High Gas Pipeline.

The Shipper agrees to indemnify Utsira High Gas Pipeline and the Operator against all suits, judgements, actions, debts, accounts, damages, costs, losses and expenses arising from or out of any legal claims of any and all persons to or against the Gas. Utsira High Gas Pipeline shall, within a reasonable time after receiving notice of the assertion of any such claim, notify the Shipper of such fact and shall permit them to participate in the defence against such claim.

### **9.2 Utsira High Gas Pipeline's guarantee**

Utsira High Gas Pipeline guarantees that the Gas redelivered to the Shipper at the Exit Point(s) shall be free from all claims of any kind and nature, except in case any such claims existed at the time of receipt by Utsira High Gas Pipeline.

Utsira High Gas Pipeline agrees to indemnify the Shipper against all suits, judgements, actions, debts, accounts, damages, costs, losses and expenses arising from or out of any legal claims of any and all persons to or against said Gas except to the extent such claim or defects are attributable to the Gas which the Shipper delivered or caused to be delivered to Utsira High Gas Pipeline hereunder and existed at the time of such delivery. The Shipper shall, within a reasonable time after receiving notice of the assertion of any claim, notify Utsira High Gas Pipeline of such fact and shall permit it to participate in the defence against such claim.

## **10 LIABILITY AND INSURANCE**

### **10.1 Risk of loss of Gas**

Risk of loss of and damage to the Shipper's Gas shall at all times be and remain with the Shipper.

For the purpose of determining any risk or liability under the Transportation Agreement, the Gas delivered shall be deemed to be situated in the Transportation System in accordance with the Booked Exit Capacity.

### 10.2 Shipper's indemnification right

Utsira High Gas Pipeline shall indemnify and hold the Shipper and/or its Agents, and/or its Contractors and/or Subcontractors and any of the aforesaid's employees, harmless from and against any loss, damage and/or expense arising out of any claim for;

- a) injuries to or death of any employees of the Participants and/or the Operator, and/or their Contractors and/or Subcontractors, and/or
- b) loss of or damage to the property of Utsira High Gas Pipeline and/or the Operator, and/or their Contractors and/or Subcontractors, and any of the aforesaid's employees, and/or
- c) all indirect losses, which include but are not limited to loss of profit, to Utsira High Gas Pipeline and/or the Operator, and/or their Contractors and/or Subcontractors and any of the aforesaid's employees,

arising out of or in connection with the Transportation Agreement, including the non-performance by the Shipper of any of its obligations, except where such claim is a result of gross negligence or wilful misconduct by the managerial and/or supervisory personnel of the Shipper and/or its Agents, its Contractors and/or Subcontractors.

### 10.3 Utsira High Gas Pipeline's and the Operator's indemnification right

The Shipper shall indemnify and hold Utsira High Gas Pipeline and the Operator, and/or their Contractors and/or Subcontractors and any of the aforesaid's employees, harmless from and against any loss, damage and/or expense arising out of any claim for;

- a) injuries to or death of any employees of the Shipper and/or its Agents, its Contractors and/or Subcontractors, and/or
- b) loss of or damage to the property of the Shipper and/or its Agents, its Contractors and/or Subcontractors, and any of the aforesaid's employees, and/or
- c) all indirect losses, which include but are not limited to loss of profit, to the Shipper and/or its Agents, its Contractors and/or Subcontractors, and any of the aforesaid's employees,

arising out of or in connection with the Transportation Agreement, including the non-performance by Utsira High Gas Pipeline or the Operator of any of its obligations, except where such claim is a result of gross negligence or wilful misconduct by the managerial and/or supervisory personnel of the Participants or the Operator and/or their Contractors and/or Subcontractors.

#### 10.4 Not in use

#### 10.5 Liability for Off-spec Gas

Notwithstanding Article 10.2, the Shipper having delivered Off-spec Gas shall be liable for any loss of Gas and/or direct costs to Utsira High Gas Pipeline caused by or resulting from the deliveries of Off-spec Gas. If the Shipper's Gas is delivered in an Off-spec Gas commingled stream, the Shipper shall be liable pro rata to its share in the Off-spec Gas commingled stream, unless;

- a) the Operator in a joint statement from all shippers delivering Gas in the commingled stream has been instructed to distribute such liability otherwise, or
- b) the Shipper, or a group of shippers, stipulates another distribution of liability within 10 Business Days after the Operator have informed about the intention to distribute the liability pro rata to the share in the Off-spec Gas commingled stream, and none of the other shippers concerned have objection to this within 10 Business Days following notice of such other distribution.

The Operator shall endeavour to minimise such costs and losses.

#### 10.6 Escape of Gas

Notwithstanding Articles 10.2 and 10.3, but subject to the second and third paragraph of this Article 10.6, all expenses and damages which may be incurred by either of the Parties as a result of environmental pollution, explosion, fire or any other events arising out of the escape of Gas from the Transportation System shall be divided between all shippers of Gas in the Transportation System as determined in accordance with Article 10.9.

Notwithstanding Article 10.2 and the first paragraph of this Article 10.6, if such pollution, explosion, fire or other events are caused by an act or omission by the Shipper, then the Shipper shall be held liable, provided, however, that each shipper, including the Shipper, shall indemnify and hold Utsira High Gas Pipeline and the Operator harmless from and against expenses and damages incurred as a result thereof as determined in accordance with Article 10.9. The Shipper hereby accepts and agrees to indemnify Utsira High Gas Pipeline and the Operator in such manner.

However, if such expenses and damages are caused by gross negligence or wilful misconduct by the managerial and/or supervisory personnel of Utsira High Gas Pipeline and/or the Operator, their Contractors and/or Subcontractors, then Utsira High Gas Pipeline shall indemnify the Shipper.

Irrespective of the liability principles stated above, all expenses and damages which may be incurred as a result of environmental pollution, explosion, fire or any other events arising out of the escape of Gas from the Transportation System shall be recovered under the insurances arranged by Utsira High Gas Pipeline pursuant to Article 10.7 up to the maximum limits of such insurances as stipulated in the Desk Quotation.

To the extent such expenses and damages can be recovered under the insurances arranged by Utsira High Gas Pipeline pursuant to Article 10.7, such recovered amounts shall be credited the shippers pro rata to each shipper's liability in respect of such expenses and damages as determined in accordance with Article 10.9.

If the total loss exceeds the maximum limits as stipulated in the Desk Quotation, then the shippers will be responsible for the excess amount as calculated in accordance with Article 10.9.

### **10.7 Insurance**

Utsira High Gas Pipeline shall be responsible for arranging all insurance in respect of the Transportation System, as well as Third Party liability insurance covering liabilities arising out of or in connection with any activity or omission related to the Transportation Agreement.

All such insurance shall contain waivers of all rights of subrogation in favour of the Shipper (including its Affiliated Companies) and/or its Agents, its Contractors and/or Subcontractors, and any of the aforesaid's employees. Further, such insurance shall specify that the shippers' liabilities under Article 10.6 shall be covered under the insurance up to the respective maximum limit as stipulated in the Desk Quotation.

The Shipper shall be responsible for arranging all insurance in respect of the property of the Shipper.

All Shipper's insurances shall contain waivers of all rights of subrogation in favour of Utsira High Gas Pipeline, the Participants (including their Affiliated Companies) and the Operator, and/or their Contractors and/or Subcontractors, and any of the aforesaid's employees.

Utsira High Gas Pipeline and the Shipper shall upon request submit to the Operator their insurance programmes relevant to the Transportation Agreement and undertake to inform the Operator of changes made therein.

### **10.8 Utsira High Gas Pipeline's liability**

The liability of each Participant related to the Transportation Agreement shall be several, according to its ownership interest in Utsira High Gas Pipeline at any time, and not joint or collective.

### **10.9 Shippers' shared liability**

The liability for expenses and damages for which neither an individual shipper nor Utsira High Gas Pipeline can be held liable according to the Transportation Agreement and, subject to Article 10.6 third paragraph, the liability for expenses and damages which may be incurred by either of the Parties as a result of environmental pollution, explosion, fire or any other events arising out of the escape of Gas from the Transportation System as described in Article 10.6, shall be shared between the shippers. The Shipper's liability shall be determined according to its share of the total Booked Exit Capacity in the Transportation System for the 365 Days preceding the Day when the event causing expenses, losses and/or damages occurred.

## **11 FORCE MAJEURE**

### **11.1 Force Majeure**

Force Majeure shall mean any event beyond Utsira High Gas Pipeline's and the Operator's control related to the Transportation System and the operation thereof or any event beyond the Shipper's control related to the Shipper's Facilities and the operation thereof that the Operator or the Shipper, as the case may be, could not reasonably be expected to have taken into account at the time when the relevant Booking(s) was made.

### **11.2 Relief due to Force Majeure**

As long as and to the extent a Party is rendered unable to perform any of its obligations due to Force Majeure, the Party shall be relieved from liability for failure to perform such obligations other than obligation of payment of money.

A Party rendered unable wholly or in part to make any payment due and payable, shall not be relieved from its obligation to pay interest, according to the interest rate given in Article 6.3, for the period from the due date of payment until payment is actually made.

### **11.3 Notification and Remedies**

A Party claiming relief on account of Force Majeure shall;

- a) as soon as practical give notice to the other Party of the event said to constitute Force Majeure, such notice including information about the circumstances and a statement of the steps and time believed necessary to remedy the Force Majeure situation and afford reasonable facilities for a site inspection if desired at the expense and risk of the Party making examination, and
- b) proceed with diligence and at its own expense to take steps to remedy the failure as soon as possible in a Reasonable and Prudent manner, provided always that no Party shall be required to make more than commercially reasonable investments nor shall it be

obligated to settle any labour dispute except in such manner as it shall in its own judgement think fit.

#### **11.4 Long term Force Majeure**

If a Party due to an event of Force Majeure has been rendered unable to perform any of its obligations for a period of 24 consecutive Months, either Party shall have the right, after the expiry of such period, to terminate the part of the Transportation Agreement affected by Force Majeure.

## **12 MISCELLANEOUS**

### **12.1 Notices**

Any notice or other communication required or permitted to be given pursuant to the Transportation Agreement shall be in writing and may be given by delivering the same by hand or by sending the same by prepaid first class post or electronic mail to the relevant address or electronic mail address set out in the Company Agreement or such other address or electronic mail address as any Party may give in writing, from time to time, to the other in accordance with this Article 12.1.

Any such notice, given as aforesaid, shall be deemed to have been given or received at the time of delivery if delivered by hand, at the time at which confirmation of successful delivery is received if sent by electronic mail and on the 5<sup>th</sup> Business Day next following the day of sending if sent by prepaid first class post. The use of electronic mail for transfer of documents shall at all times be in accordance with internationally recognised standards as may be adopted by the Operator. The chosen standard shall enable the use of digital signatures or similar electronic safety device, encryption, filing and retrieving.

### **12.2 Notice in case of restructuring**

If the Shipper initiate a merger, dissolution, liquidation, winding up, reduction of share capital or a similar process that is likely to have an adverse effect on the Shipper's ability to fulfil its obligations under the Transportation Agreement, or suffers a material credit rating downgrade also after the Shipper's last Booking Period has expired, the Shipper shall give notice to the Operator immediately after such process have been initiated and / or such credit rating downgrade has occurred.

### **12.3 Confidentiality**

Confidential Information shall not be disclosed by the Shipper or the Operator to any Third Party, or by the Operator to any of the Participants. However, the Confidential Information may be disclosed by;

- a) the Operator to;



- (i) the Agent or Affiliated Company of the Shipper,
- (ii) the Contractors and/or Subcontractors of the Operator to the extent disclosure is required for the proper execution of their work,
- (iii) the advisers of the Operator or to arbitrators to the extent it is required for the proper execution of their assignments, or
- (iv) governmental authorities in connection with required reports.

b) the Shipper to;

- (i) the Agent or any Affiliated Company of the Shipper,
- (ii) any bona fide potential buyer of the Shipper's Gas or an interest in the sources delivering Gas under the Transportation Agreement,
- (iii) any bona fide potential assignee of the Shipper's Transportation Agreement,
- (iv) any relevant institution in connection with the borrowing of funds or issuance or sale of security,
- (v) the stock exchanges on which any securities of the Shipper are or may be quoted to the extent required by the applicable rules of such stock exchanges,
- (vi) the advisers of the Shipper or to arbitrators to the extent it is required for the proper execution of their assignments, or
- (vii) any governmental authorities in connection with required reports.

Notwithstanding the above, the Operator may;

- a) provide to the relevant field operator historical lifting data in order to maintain the gas lifting account,
- b) provide Confidential Information that has both been made anonymous and aggregated with other shippers' confidential information,
- c) at any time in connection with bona fide legal disputes arising out of the Transportation Agreement, provide the Participants with any relevant Confidential Information.

Where disclosure of Confidential Information is made to a Third Party or Participant, the disclosing Party shall ensure that appropriate safeguards are undertaken to prevent the Third Party or the Participant, as the case may be, from making any further disclosure of such information.

#### **12.4 Telecommunications and data transmission**

The Shipper shall, at its own cost and expense, install or ensure that necessary telecommunication equipment according to the Operator's specifications is installed. Any necessary changes to agreed telecommunication equipment shall be discussed with the Shipper before implemented.

#### **12.5 Time reference**

Any reference to time shall be to the time in force in Norway.

#### **12.6 Amendments to the Terms and Conditions including the Appendices**

Amendments to the Terms and Conditions including the Appendices are subject to approval by the Ministry. Proposals for such amendments shall be developed by the Operator. Before any such proposals are submitted to the Ministry the Operator shall submit the proposals in writing for consultation in accordance with "*Forskrift 27. juni 1997 nr. 653 til lov om petroleumsvirksomhet*", section 65, second paragraph.

The Shipper shall submit its comments within 20 Business Days after receipt of such notice from the Operator. The Operator shall take due consideration of the Shipper's comments and submit them to the Ministry, along with the proposals.

The amendments shall enter into force as determined by the Ministry.

### **13 TERM OF AGREEMENT**

#### **13.1 Termination of the Transportation Agreement**

The Transportation Agreement shall terminate on the earlier of;

- a) the date when the Shipper's last Booking Period has expired,
- b) the date Utsira High Gas Pipeline ceases to own and operate the Transportation System provided Utsira High Gas Pipeline has given 24 months prior notice of said event,
- c) the date when the licence period for the Transportation System expires, or
- d) the date specified in the termination notice issued according to Article 6.5 or on date of termination according to Article 6.6 or Article 11.4.

#### **13.2 Survival of Termination**

The termination shall be without prejudice to any payment obligation being unfulfilled or any liability incurred and not paid at the date of termination.

The Parties rights and obligations according to Articles 6.8 and 12.3 shall remain for a period of 3 years from the date of termination.

The Shipper's obligation according to Articles 5.4 and 12.2 shall survive the termination of the Transportation Agreement.

## **14 ASSIGNMENT**

The Shipper may only assign its rights and obligations under the Transportation Agreement subject to prior written consent from Utsira High Gas Pipeline.

Notwithstanding the above, the Shipper may assign its rights and obligations to unused Booked Capacity provided that;

- a) the Operator has confirmed that the assignee;
  - (i) is a Financially Qualified Company,
  - (ii) has entered into a Company Agreement, and
  - (iii) fulfils the requirements in the Booking Manual for obtaining Booked Capacity in the secondary market,

and,

- b) the assignee has accepted to be bound by the Transportation Agreement.

For the avoidance of doubt, an assignment of ownership to the Transportation System entails a corresponding assignment of rights and obligations under the Transportation Agreement.

## **15 APPLICABLE LAW AND ARBITRATION**

The Transportation Agreement shall be governed and construed in accordance with Norwegian law.

Any controversy or dispute that may arise in connection with or as a result of the Transportation Agreement and which cannot be resolved by mutual agreement between the Parties shall be finally decided by arbitration in Stavanger in accordance with Norwegian Arbitration Act of 14 May 2004 No 25 ("Lov om voldgift"), as subsequently amended or replaced. Unless otherwise agreed, the arbitration proceedings, documents and correspondence in connection with the arbitration and awards delivered pursuant to this Article 15 are confidential in accordance with the confidentiality provisions herein.

Documents and statements in the Norwegian and English language shall be allowed in any procedure involving arbitration. Translation thereof shall be at the expense of the Party requesting such translation.

**APPENDIX A**

**TO**

**TERMS AND CONDITIONS**

**FOR**

**TRANSPORTATION**

**OF GAS**

**IN**

**UTSIRA HIGH GAS PIPELINE**

**\*\*\***

**OPERATIONS MANUAL**

## TABLE OF CONTENTS

<b>1</b>	<b>APPLICABILITY, DEFINITIONS, PRIORITIES AND AMENDMENTS.....</b>	<b>3</b>
1.1	Applicability.....	3
1.2	Definitions .....	3
1.3	Relation to the Shipper Manual.....	4
<b>2</b>	<b>NOMINATIONS .....</b>	<b>4</b>
2.1	Forecasts.....	4
2.2	Availability .....	5
2.3	Daily Nominations and re-nominations .....	5
2.4	Reporting.....	5
2.5	Planned Maintenance.....	6
2.6	Meetings.....	6
2.7	Coordination .....	6
<b>3</b>	<b>OPERATIONS.....</b>	<b>7</b>
3.1	Obligations prior to commencement of Transportation Services.....	7
3.2	Capacity tests .....	7
3.3	Transportation Curtailment .....	7
3.4	Interruption.....	8
<b>4</b>	<b>OPERATING CONDITIONS AND QUALITY REQUIREMENTS.....</b>	<b>8</b>
4.1	Requirements at the Entry Point(s).....	8
4.2	Requirements at the Exit Point(s).....	8
4.3	Combination of Gas in order to meet the quality requirements.....	8
<b>5</b>	<b>MEASUREMENTS, TESTS AND ANALYSES.....</b>	<b>9</b>
5.1	General.....	9
5.2	Measurements, tests and analyses at the Entry Point(s).....	9
5.3	Measurements, tests and analyses at the Exit Point(s).....	9
5.4	Facilities upstream of the Entry Point(s).....	9
5.5	Facilities downstream of the Entry Point(s) .....	10
5.6	Design of measurement facilities .....	10
5.7	Maintenance, calibration and measurement errors .....	11
5.8	Analysis .....	12
5.9	Codes and standards.....	13
<b>6</b>	<b>ALLOCATION OF SHIPPER’S GAS.....</b>	<b>15</b>
6.1	Gas allocation.....	15
<b>7</b>	<b>TABLES .....</b>	<b>17</b>
7.1	Entry specifications .....	17
7.2	Exit specifications .....	18

# 1 APPLICABILITY, DEFINITIONS, PRIORITIES AND AMENDMENTS

## 1.1 Applicability

This Operations Manual sets out the operational regulation regarding the Shipper's and Utsira High Gas Pipeline's rights and obligations given in the Terms and Conditions.

The Operator will execute Utsira High Gas Pipeline's rights and obligations according to this Operations Manual.

## 1.2 Definitions

The definitions set out in the Terms and Conditions applies to this Operations Manual. In addition, the following terms shall have the meaning ascribed to them below:

"Accounting Period" shall mean one Day.

"Components" means nitrogen, carbon dioxide, methane, ethane, propane, iso-butane, normal butane, iso-pentanes, normal pentane, hexane, heptane, octanes, nonanes, decanes and heavier hydrocarbons.

"Entry Point Availability" shall mean the quantity of Gas that at a given point in time can be delivered from a Field at an Entry Point.

"Exit Point Availability" shall for any Exit Point mean the quantity of Rich Gas that Utsira High Gas Pipeline at a given time is able to redeliver to all shippers at that Exit Point.

"Field" shall mean any production facility producing Gas for deliveries to Utsira High Gas Pipeline for Transportation Services.

"Operational Services" shall mean adjustment of Linefill quantity.

"Shipper's Field Operator" shall mean the operator of the Shipper's Field(s).

"Shipper's Field" shall mean the production facilities producing Shipper's Gas for deliveries, either directly to or through transportation and/or processing facilities upstream of the Entry Point(s) for the Shipper's Gas, to the Transportation System, whether the production facilities are owned by the Shipper or not.

"Significant Systematic Error" shall mean a Systematic Error that exceeds 0,02 per cent of total mass flow provided that the economic value of the error is greater than the cost of correcting such error.

"Systematic Error" shall mean a detected error in a measurement result that is not corrected by the measurement model and that is caused by issues such as:

- failure of measurement equipment (equipment that does not meet performance requirements)
- non-compliance with internal requirements and routines (management system)
- incorrectly read values
- errors in calculations
- incorrectly entered parameters in computer system (incorrect parameters used in calculations)

For the avoidance of doubt, if routine recalibrations tests reveal any deviations compared to previous measurement results, such deviations shall normally not be considered a Systematic Error.

“Transportation Curtailment” shall mean any event affecting the Transportation System, including, but not limited to, events described in the Terms and Conditions Articles 2.5, 2.6, 2.7, or Force Majeure, that reduces the capacity in the Transportation System.

### 1.3 Relation to the Shipper Manual

The regulations set out in the Operations Manual are supplemented by the Shipper Manual. In case of conflict between the Operations Manual and the Shipper Manual, the regulation in the Operations Manual shall unless otherwise expressly stated, always prevail.

## 2 NOMINATIONS

### 2.1 Forecasts

Forecast according to this article 2.1 shall have content and be in accordance with time limits as described in the Shipper Manual.

The Shipper shall issue, or provide Shipper’s Field Operator to issue, to the Operator:

- Long-term forecasts
- Monthly forecasts (15-month rolling)
- Weekly forecasts

of its deliveries of Gas at each Entry Point.

The forecasts shall in all aspects be consistent with the relevant forecasts submitted to the Norwegian authorities.

The Shipper shall ensure that the Shipper’s Field Operator(s) informs the Operator of relevant plans for maintenance, tests, shut-down, temporary periods of decreased/increased deliveries of Gas, and the time and duration for such events, as soon as such information is available.

The Operator shall inform the Shipper of programmes for planned maintenance, shut-downs, tests and any other activities related to the Transportation System and Fields which could affect the Entry Point Availability and/or the Exit Point Availability or otherwise influence delivery and/or redelivery of Shipper's Gas.

## **2.2 Availability**

The Operator shall inform the Shipper daily of its available quantities of Gas at Shipper's Field(s).

The Shipper shall ensure that the Shipper's Field Operator daily informs the Operator of the available quantities of Gas at the relevant Entry Point(s).

## **2.3 Daily Nominations and re-nominations**

The Shipper shall submit to the Operator its Daily Nominations, except for Interruptible Capacity, for each Day before 14:00 hours on the preceding Day.

The Shipper shall submit to the Operator its Daily Nominations for Interruptible Capacity in accordance with the procedure described in the Shipper Manual.

The Daily Nominations shall specify deliveries and redeliveries in energy units and shall have a content as further described in the Shipper Manual.

The Operator shall accept the Shipper's Daily Nomination submitted within the deadline in the first paragraph. If the Shipper after the deadline makes a re-nomination, the Operator shall use reasonable endeavours to accept the re-nomination. If the Operator accepts the re-nomination, the re-nomination shall be deemed to be a Daily Nomination.

Further the Operator has a right to refuse Shipper's Daily Nominations for the Exit Point if the Gas to be redelivered at the Exit Points will not comply with the relevant Specifications, unless the Shipper accepts redelivery of Off-spec Gas and such acceptance does not affect the redelivery of Gas to the other shippers at such Exit Point. The Shipper accepting redelivery of such Off-spec Gas shall be liable for any consequences resulting from acceptance of such Off-spec Gas redeliveries.

Unless otherwise agreed with the Operator, the Shipper shall not be entitled to nominate deliveries or redeliveries of Gas as an uneven flow-rate throughout the Day.

The nomination procedure is further described in the Shipper Manual.

## **2.4 Reporting**

The Operator shall on a daily basis notify the Shipper of the Shipper's Gas delivered at the Entry Point(s) and redelivered at the Exit Point(s) on the previous Day.



The Shipper shall ensure that the Shipper's Field Operator(s) on a daily basis notifies the Operator of the quantity of Gas delivered at the relevant Entry Point(s) on the previous Day.

The Shipper shall notify the Operator of the date and time of any Bilateral Transactions as soon as reasonably practical. Any Bilateral Transactions that takes place within Day shall for the purpose of these Terms and Conditions take effect as from the time the appurtenant re-nomination takes effect.

## 2.5 Planned Maintenance

The Operator shall each calendar year during the period between May and December discuss with the Shipper the maintenance plan for the following two calendar years. The decision on the duration of and the reduction in Transportation Services during the Maintenance Period(s) shall be made solely by the Operator. However, when deciding upon the Maintenance Period(s) the Operator shall inter alia take into account;

- a. that the Maintenance Period(s) shall be determined with the objective to minimise disruption to the Transportation Services to the extent possible,
- b. the need for maintenance of the Fields,
- c. the need for maintenance of the Transportation System, any downstream receiving terminal(s) and/or other adjacent transportation systems,
- d. the need for maintenance of facilities used for onshore transportation of Gas.

The Operator shall before 16 December in each calendar year submit a notice to the Shipper stating the Maintenance Period(s), any possible quality implications and the transportation capacity available to the Shipper on each Day of the Maintenance Period(s) for the following two calendar years.

## 2.6 Meetings

The Operator and the Shipper shall, if requested, meet in order to discuss subjects related to the delivery and redelivery of Gas under the Transportation Agreement.

The schedules for meeting and for exchanging information may be adjusted to coincide with the Shipper's procedure(s) for reporting to the Norwegian authorities.

Furthermore, the Operator and the Shipper shall meet when requested by the Shipper.

## 2.7 Coordination

The Operator and the Shipper shall coordinate their activities regarding necessary Gas quantities to be delivered to the Transportation System to meet the Shipper's requirements for redelivery of Gas pursuant to article 2. The Shipper shall ensure that the relevant Shipper's Field Operator(s) participate in such coordination activities.

### 3 OPERATIONS

#### 3.1 Obligations prior to commencement of Transportation Services

Prior to the commencement of the Transportation Services:

- a. The Shipper shall at the Operator's request provide evidence to the Operator that telemetry and communication facilities for monitoring of the operating conditions and the quality of Gas to be delivered at the Entry Point(s) are in good operational order;
- b. The Shipper shall make available to the Operator the necessary analysis and test results to verify that the Gas to be delivered at the Entry Point(s) is within the Specifications as set forth in article 4.1. The requirements according to this article 3.1 shall also upon the Operator's request apply after any major shut-off;
- c. The Operator shall at the Shipper's request provide evidence to the Shipper that telemetry and communication facilities for monitoring of the operating conditions and the quality of Gas at the Exit Point(s), except for Exit Point 1, are in good operational order;
- d. The Operator shall at the Shipper's request, allow for connection of the downstream transportation system operator's telemetry systems to the Transportation System for exchange of relevant telemetry signals.

#### 3.2 Capacity tests

The Operator shall be entitled to perform capacity tests in the Transportation System. If such tests would require changes or stable conditions in Gas delivery and/or redelivery, the Shipper shall in cooperation with the Shipper's Field Operators use reasonable endeavours to comply with requests for such changes.

#### 3.3 Transportation Curtailment

In the event of Transportation Curtailment, the Operator shall calculate the new Entry Point Availability and / or Exit Point Availability, for the Shipper and inform the Shipper without delay.

The Shipper's new Entry Point Availability shall be calculated as its pro rata share of all shippers' Booking at the affected Entry Point for the Day for which the total Entry Point Availability is reduced.

The Shipper's new Exit Point Availability shall be calculated as its pro rata share of all shippers' Bookings at the affected Exit Point for the Day for which the total Exit Point Availability is reduced.

In case of Transportation Curtailment after the Day has started the already delivered, processed and / or redelivered quantities of Gas shall be allocated to the Shipper in accordance with its Daily Nominations, for the period prior to the point in time when the Transportation Curtailment occurred.

Notwithstanding the above, Firm 2 Capacity, as defined in the Booking Manual, has a lower curtailment priority and shall be curtailed first.

### **3.4 Interruption**

In case of interruption of Interruptible Capacity, the Operator shall calculate the Shipper's new reduced capacity at the relevant Entry Point and / or Exit Point as its pro rata share of all shippers' Interruptible Booking at the relevant Entry Point and / or Exit Point for the Day for which the Interruptible Capacity is reduced.

In case of interruption after the Day has started the already delivered and / or redelivered quantities of Gas shall be allocated to the Shipper for the period prior to the point in time when the interruption occurred.

## **4 OPERATING CONDITIONS AND QUALITY REQUIREMENTS**

### **4.1 Requirements at the Entry Point(s)**

The operating conditions and quality specifications in article 7.1 shall apply (the "Specifications").

In addition, the Gas shall be free from radioactivity, odours (as determined by nationally recognised standards), other noxious contaminants such as corrosion/scale inhibitors, flow enhancers, alcohol, hydrate inhibitors, emulsion breaking or stabilising elements or other substances which might cause damage to or interference with the proper operation of facilities through which it flows. Exception could be granted for these requirements if the Shipper accept to receive such Gas at the Exit Point.

### **4.2 Requirements at the Exit Point(s)**

The operating conditions and quality specifications in article 7.2 shall apply (the "Specifications").

If the Operator redelivers or expects to redeliver Off-spec Gas to the Shipper, the Operator shall inform the Shipper as soon as possible.

### **4.3 Combination of Gas in order to meet the quality requirements**

The Operator shall use reasonable endeavours to commingle Gas within the Transportation System and, if applicable, at the Exit Point(s) to ensure that the Specifications at the Exit Point(s) can be met.

The Operator shall advise the Shipper how to combine its sources of Gas in order to comply with the Specifications at the Entry Point(s) and the Exit Point(s). However, the responsibility to ensure such compliance stays with the Shipper.

## 5 MEASUREMENTS, TESTS AND ANALYSES

### 5.1 General

Subject to governmental regulations, all measurement, testing, on-line analysis and sampling facilities and procedures necessary to monitor the Gas quality and perform allocation of Shipper's Gas according to article 6, shall be in accordance with this article 5. The procedures shall be made on the basis of high and consistent accuracy between measurement, test, on-line analysis and sampling of the Gas streams.

### 5.2 Measurements, tests and analyses at the Entry Point(s)

In order to monitor the operating conditions and the quality of the Gas to be delivered at the Entry Point(s), the Shipper shall carry out or cause to be carried out on its behalf necessary measurements, analyses and tests in the manner and frequency as requested by the Operator and shall have results from such measurements, analyses and tests transmitted to the Operator.

Relevant data and specifications for any measuring facilities required upstream the Entry Point(s) to perform such monitoring of the operating conditions and the quality of the Gas shall be subject to review by the Operator.

### 5.3 Measurements, tests and analyses at the Exit Point(s)

Operation condition and quality of the Gas at Exit Point 1 will be established by calculating the difference between the operation condition and quality of all Gas into the Transportation System and operation condition and quality of all other Gas streams out of the Transportation System.

### 5.4 Facilities upstream of the Entry Point(s)

The Shipper shall, at its own expense, have or ensure to have measurement, testing, on-line analysis and/or sampling facilities installed maintained and operated upstream of the Entry Point(s). The design, installation and operation of said facilities shall be subject to approval by the Operator. Such approval shall not be unreasonably withheld or delayed.

The Shipper shall ensure that the Operator have access at reasonable times to said facilities to witness the calibrations and tests and to observe the operation of the measurement, testing, on-line analysis and/or sampling facilities installed upstream the Entry Point(s). The Shipper shall furnish the Operator, at its request and for its audit, any and all metering data and other test information applicable to said facilities reasonably necessary for verification of the measurements contemplated in this article 5.4.

In the event the Shipper or the Shipper's Field Operator(s) experience a malfunction of its measurement, testing, on-line analysis and/or sampling facilities which may affect the accuracy of measurement, the Shipper shall ensure that the Shipper's Field Operator(s) as soon as practically possible advise the Operator of the same. In such a case, the Gas quantities delivered shall be estimated by the respective Shipper's Field Operator(s) and approved by the

Operator. In the event that the malfunction prevents the Operator from properly allocating the received quantities to each shipper in accordance with article 6 and the malfunction cannot be corrected within a period of time acceptable to the Operator and as notified to the Shipper, then deliveries hereunder shall cease until such time as the malfunction has been corrected to the satisfaction of the Operator and the Operator has notified the Shipper that deliveries may be resumed.

## **5.5 Facilities downstream of the Entry Point(s)**

The Operator shall arrange at its expense, with respect to all deliveries within and redeliveries from the Transportation System and/or any downstream receiving terminals, to have all measurement, testing, on-line analysis and/or sampling facilities installed, operated and maintained downstream the Entry Point(s). All tests and other procedures according to this article necessary for allocation and accounting of Shipper's Gas in accordance with article 6 shall be performed in strict compliance herewith at each point where measurement, testing, on-line analysis and/or sampling facilities are installed in the Transportation System and/or any downstream receiving terminal(s) for allocation of Shipper's Gas.

Furthermore, at the request of the Shipper, the Operator will give reasonable notice to permit representatives of the Shipper to witness calibrations and tests, and to observe the operation of the relevant measurement, testing, on-line analysis and/or sampling facilities for allocation and accounting of Shipper's Gas and the Operator shall also furnish to the Shipper at its request and for its audit, any and all metering data and other analyses and testing information applicable to said facilities, reasonably necessary for the verification of the measurements contemplated in this article 5.5.

This Article 5.5 is not applicable for measurement, testing, on-line analysis and/or sampling facilities at or downstream Exit Point 1.

## **5.6 Design of measurement facilities**

Subject to governmental regulations, the following principles shall apply for the metering equipment used for allocation of Shipper's Gas in the Transportation System.

The mass of Gas for all deliveries related to the allocation of the Shipper's Gas, shall be measured fiscally.

Fiscal metering systems shall be designed according to one of the following principles;

- orifice meters in accordance with ISO 5167,
- turbine meters for gas in accordance with ISO 9951 and AGA 7,
- turbine meters for liquids in accordance with API MPMS,
- ultrasonic meters according to relevant standards, or

- any other design agreed between the Operator and the shippers.

Any metering system shall be designed and constructed to have a high and consistent accuracy.

The design of any metering system to be used for the above purposes shall be approved by the Operator.

## **5.7 Maintenance, calibration and measurement errors**

### **5.7.1 Maintenance and calibration**

To ensure that measurement accuracy is maintained within tolerance limits, all measurement equipment shall be maintained and operated in accordance with;

- governmental regulations,
- applicable codes,
- manufacturer's specifications,
- the Operator's requirements related to fiscal metering, and
- the Shipper's Field Operator's own requirements and procedures.

Tolerance limits are specified in the same regulations, codes, specifications and requirements as described above.

Calibration tests of the measurement equipment shall be performed in accordance with the above , and as agreed with the relevant operator(s) of the Field(s).

Any Shipper whose interests may be affected by a measurement error may request the Operator to initiate special tests of the above measurement equipment in addition to the agreed regularly scheduled tests. The expense of any such special test shall be borne by the Shipper requesting such special test, unless such test shows that the error in the total mass flow, caused by a component being in error or out of calibration, exceeds 0.4 per cent, in which case the expense of the special test shall be included as normal operating cost in the Transportation System.

### **5.7.2 Measurement errors etc.**

If any measurement equipment is out of service and the quantity of Gas delivered is not correctly indicated by the reading thereof, the quantity delivered, during such period, shall be estimated by the operator of the measurement equipment in question on the basis of the best data available

- by using the registration of any check/backup measurement equipment, or

- by correcting the error if the percentage of error is ascertainable by calibration, test or mathematical calculations, or
- by estimating the quantity of delivery by deliveries during preceding and/or subsequent periods under similar conditions when the measurement equipment was in service.

If a measurement error is detected, the relevant measurement equipment shall be replaced, repaired or adjusted to record accurately, as determined appropriate by the Operator.

In case of Significant Systematic Errors, previous recordings shall be corrected for the relevant period. If it is not possible to document how long such error has persisted, the corrections shall be performed for half the time elapsed since the date of the last test.

## 5.8 Analysis

Analyses for allocation of Shipper's Gas shall be established by on-line chromatography, or by analysing flow proportional composite samples from the streams in question.

On-line gas chromatographs shall be operated and maintained according to applicable standards and best practices..

Any analysis to be used in the allocation Shipper's Gas shall be representative for the stream and time in question.

The gas shall be analysed by gas chromatography according to ASTM 1945 latest version, to determine the content of;

- nitrogen,
- carbon dioxide,
- methane,
- ethane,
- propane,
- iso-butane,
- normal butane,
- iso-pentane,
- normal pentane,
- hexanes and heavier components.

Hexanes and heavier components shall be further analysed if necessary to meet requirements in the prevailing measurement regulations. In such cases, the composition shall be reported in mass % per Component to the Operator.

Due to the expected variations in flow and in gas composition, the resulting composition shall be flow weighted, either by performing flow proportional sampling, or by combining the analyses from online gas chromatographs with the flow as metered by the fiscal metering system.

When online gas chromatograph is used, a daily flow weighted analysis shall be calculated.

For streams included in monthly allocation, a monthly flow weighted analysis shall be established.

The analysis corresponding to the relevant allocation period shall be reported to the Operator.

## 5.9 Codes and standards

Codes and standards to be used for measurement, test, on-line analysis and/or sampling of the Gas are subject to governmental regulations.

Listed below are codes which are generally accepted in the oil and gas industry, any of which may be used for the purpose herein. The Operator will inform the Shipper if a change to a newer version of any standard is prepared.

- NORSOK standard I-106  
Fiscal measurement systems for hydrocarbon liquids and gas.
- International Standard ISO 80000  
Quantities and units.
- International Standard ISO 3171  
Petroleum Liquids - Automatic Pipeline Sampling.
- International Standard ISO 5024  
Petroleum Liquids and Liquefied Petroleum Gases - Measurement -Standard reference conditions.
- International Standard ISO 5167  
Measurement of fluid flow by means of pressure differential devices inserted in circular cross-section conduits running full - Part I: General principles and requirements, Part 2: Orifice plates, Part 3: Nozzles and Venturi nozzles, Part 4: Venturi tubes.
- International Standard ISO 5168  
Measurement of Fluid Flow - Procedure for the Evaluation of Uncertainty.
- International Standard ISO 6974  
Natural Gas - Determination of composition with defined uncertainty by gas chromatography, Part 1: Guidelines for tailored analysis, Part 2: Measuring-system characteristics and statistics for processing of data, Part 3: Determination of hydrogen, helium, oxygen, nitrogen, carbon dioxide and hydrocarbons up to C8 using two packed columns, Part 4: Determination of nitrogen, carbon dioxide and C1 to C5 and C6+ hydrocarbons for a laboratory and on-line measuring system using two columns.



- International Standard ISO 6976  
Natural Gas - Calculation of Calorific Values, Density, Relative Density and Wobbe Index from composition.
- International Standard ISO 9951  
Measurement of gas flow in closed conduits - Turbine meters.
- International Standard ISO 10715  
Natural Gas - Sampling Guidelines.
- International Standard ISO 10790  
Measurement of fluid in closed conduits – Guidance to the selection, installation and use of Coriolis meters (mass flow, density and volume flow measurements).
- International Standard ISO 12213  
Natural Gas - Calculation of compression factor, Part 1: Introduction and guidelines, Part 2: Calculation using molar-composition analysis.
- AGA-7  
Measurement of Natural Gas by Turbine Meters – AGA Transmission Measurement Committee Report No. 7.
- AGA 8  
Compressibility Factor of Natural Gas and Related Hydrocarbon Gases – AGA Transmission Measurement Committee Report No. 8.
- AGA 9  
Measurement of Gas by Multipath Ultrasonic Meters – AGA Transmission Measurement Committee Report No. 9.
- AGA 10  
Speed of Sound in Natural Gas and Other Related Hydrocarbon Gases – AGA Transmission Measurement Committee Report No. 10.
- AGA 11  
Measurement of Natural Gas by Coriolis Meter – AGA Transmission Measurement Committee Report No. 11.
- ASTM D- 1945  
Analysis of Natural Gas by Gas Chromatography.
- ASTM D-3700  
Standard Test Method for Obtaining Hydrocarbon Fluid Samples Using a Floating Piston Cylinder.
- GPA Publication 2166  
Methods for Obtaining Natural Gas Samples for Analysis by Gas Chromatography.
- API Manual of Petroleum Measurement Standards  
Chapter 14 - Natural Gas Fluids Measurement.

- ISO 17089-1  
Measurement of fluid flow in closed conduits - Ultrasonic meters for gas - Part 1: Meters for custody transfer and allocation measurement

## 6 ALLOCATION OF SHIPPER'S GAS

### 6.1 Gas allocation

#### 6.1.1 Measurement scheme

The measurement scheme comprises measurement facilities at each of the Fields delivering Gas into the Transportation System.

A principles sketch of the measurement scheme is shown in Figure 1 below.

Figure 1: Transportation System measurement scheme

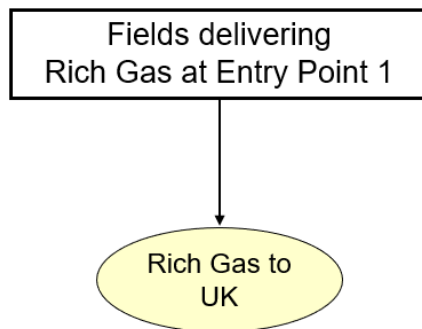

#### 6.1.2 Measuring, sampling and analysis

The Operator shall determine the total mass of each separate Gas stream mentioned in article 6.1.1.

The Shipper shall, if requested by the Operator, ensure that a verified mass and a representative analysis is obtained from each of the streams from the Shipper's Field(s) to determine the Components and any other substances as may be required for purposes of allocation of Shipper's Gas. Such mass and analysis results shall be issued to the Operator within 09:00 on the following Day.

The Shipper shall ensure that the result of sample analysis at the Shipper Field(s) is reported to the Operator for each Component as described in article 5. The Operator shall use the result of such analysis for accounting and allocation purposes.

The Operator shall for all calculations herein set the properties of combined hexanes and heavier hydrocarbons equal to normal hexane.

### 6.1.3 Allocation of Components

The streams from the Shipper's Field(s) shall be metered and analysed in accordance with article 6.1.1 during each Accounting Period. The mass of each of the individual Components in a stream shall be equal to the total mass of such stream multiplied by the mass fraction of each Component.

The Shipper's fractional share of a Component for each Shipper's Field(s) in a commingled stream shall be the mass of that Component in the input stream from the Shipper's Field(s), divided by the total mass of that Component for all input streams entering and becoming a part of the commingled streams.

When a commingled stream is split into two or more separate streams, the Shipper's fractional share of a Component for each Shipper's Field(s) shall remain the same in each such separate stream.

The Shipper's allocation percentage of the Shipper's fractional share for each Shipper's Field(s) shall be based on the Daily Nominations provided by the Shipper for the Shipper's Field(s).

In cases where there are no shipper nomination in respect of a Field the Operator will use an allocation key provided by the field operator.

### 6.1.4 Fuel Gas, Gas to flare and Replacement Gas

The Shipper shall ensure that Fuel Gas requirements at the Shipper's Field(s) shall be withdrawn upstream of the Gas metering facilities. In the event Gas is withdrawn or vented downstream of the metering facilities, it shall be appropriately accounted for by procedures approved by the Operator.

Where determinable losses occur, Replacement Gas shall be accounted for and debited the Shipper in accordance with article 6.1.3.

### 6.1.5 Reporting

The mass of each of the individual Components in the Shipper's Gas shall each Day be reported to the Shipper.

### 6.1.6 Reallocation

In case of Significant Systematic Errors or in case of other errors in the Operator's system that affect the Shipper, reallocation shall normally be performed by adjustments to the actual Month.

In case of any of the abovementioned errors having occurred more than 24 Months before the start of the current calendar year, the Operator shall decide how reallocation shall be performed, preferably by adjustments to the last 24 Months.

The Operator may, in its sole opinion, decide not to perform reallocation for errors if the cost for such reallocation exceeds the value of the error or otherwise is unreasonable.

Operator's decisions according to this article 6.1.6 are final.

## 7 TABLES

### 7.1 Entry specifications

Designation and unit	Specification	Notes
Maximum operating pressure (barg)	206	1,2
Minimum operating pressure (barg)	115	
Maximum operating temperature (°C)	60	
Maximum cricondenbar pressure (barg)	10 bar below the calculated pressure at Exit Point 1	
Maximum water content (ppm vol)	35	
Maximum carbon dioxide (mole %)	7,85	
Maximum hydrogen sulphide (ppm vol)	14,4	
Maximum O <sub>2</sub> - free O <sub>2</sub> (ppm vol)	2	
Sediment/metals	Negligible	3
Mercaptans	Negligible	3
Mercury	Negligible	3
Duodecanes or heavier	Negligible	3
Glycols	Negligible	3

<sup>1</sup> According to DNV-OS-F101 (2012)

<sup>2</sup> With current Pressure Protection System the maximum operating pressure is 172,4 barg

<sup>3</sup> For the purposes of this Specification negligible is defined as less than a concentration of the relevant species that the Shipper will have any problem to accept redelivery in accordance with Article 4.3.

## 7.2 Exit specifications

Designation and unit	Specification	Notes
Maximum operating pressure (barg)	172,4	<sup>1</sup>
Minimum operating pressure (barg)	115	
Maximum operating temperature (°C)	60	
Maximum cricondenbar pressure (barg)	10 bar below the calculated pressure at Exit Point 1	
Maximum water content (ppm vol)	63	
Maximum carbon dioxide (mole %)	7,85	
Maximum hydrogen sulphide (ppm vol)	14,4	
Maximum O <sub>2</sub> - free O <sub>2</sub> (ppm vol)	7	
Sediment/metals	Negligible	<sup>2</sup>
Mercaptans	Negligible	<sup>2</sup>
Mercury	Negligible	<sup>2</sup>
Duodecanes or heavier	Negligible	<sup>2</sup>
Glycols	Negligible	<sup>2</sup>

<sup>1</sup> According to ASME B31.8

<sup>2</sup> For the purposes of this Specification negligible is defined as less than a concentration of the relevant species that the Shipper will have any problem to accept redelivery in accordance with Article 4.3.

**APPENDIX B**

**TO**

**TERMS AND CONDITIONS**

**FOR**

**TRANSPORTATION OF GAS**

**IN**

**UTSIRA HIGH GAS PIPELINE**

**\*\*\***

**TRANSPORTATION SYSTEM DESCRIPTION**

## 1 Description of the Utsira High Gas Pipeline

The Utsira High Gas Pipeline consist of the following items:

1. A spool connecting to the seabed hub of the gas export riser on the Edvard Grieg platform
2. A 16" outside diameter pipeline connecting to the spool, approximately 94 km long
3. UHGP PLEM at SAGE-end of the pipeline
4. A spool between the UHGP PLEM and the Alvheim PLEM

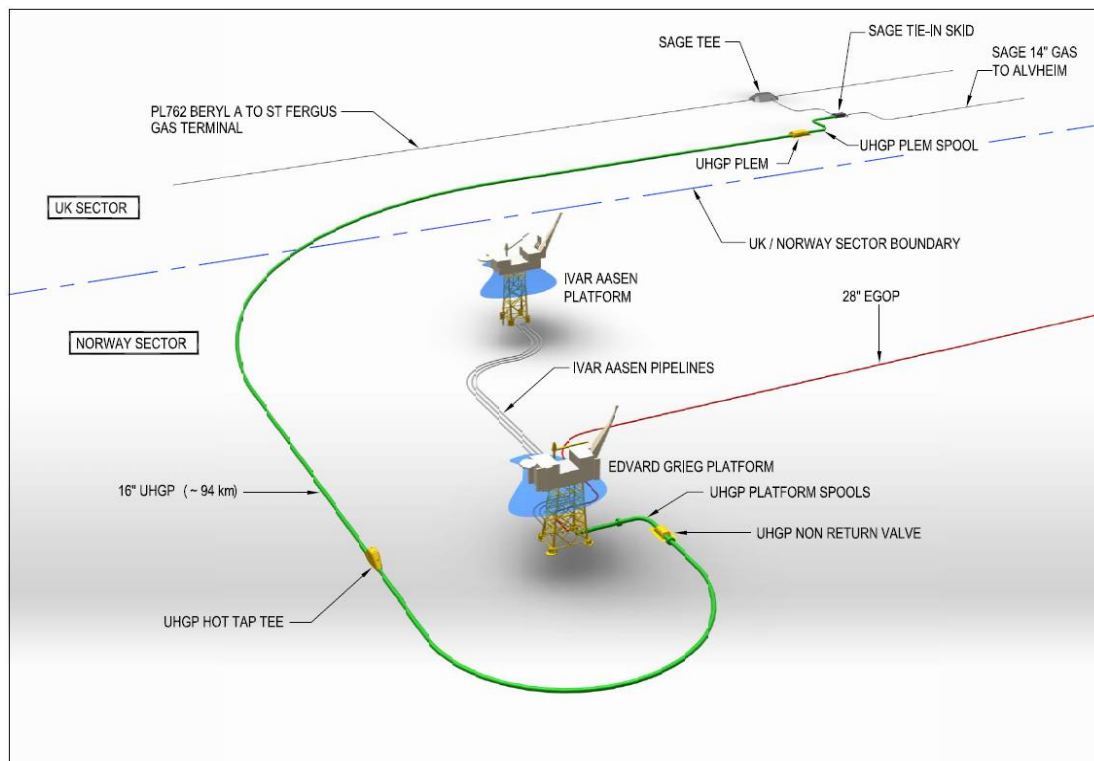

**Figure 1 Utsira High Gas Pipeline**

## 2 Entry Point 1

The Entry Point 1 is towards the Edvard Grieg platform is at the weld immediately upstream of the flanged connection at the downstream end of the Edvard Grieg gas export riser as shown in figure 2.

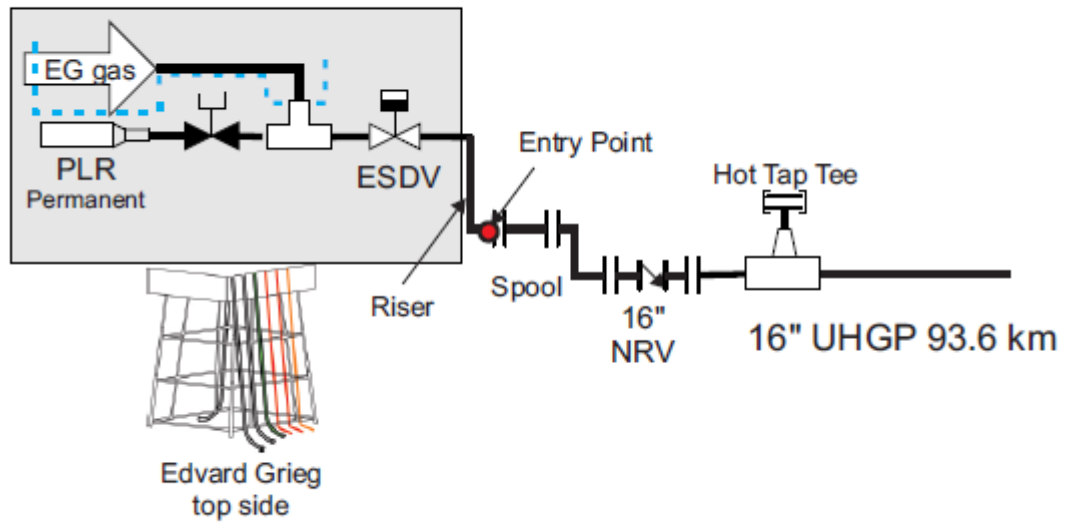

Figure 2 Entry Point 1



### 3 Exit Point 1

The Exit Point 1 is towards SAGE at the upstream flange face at the Alvheim PLEM where it is connected to the Utsira High Gas Pipeline as shown in figure 3.

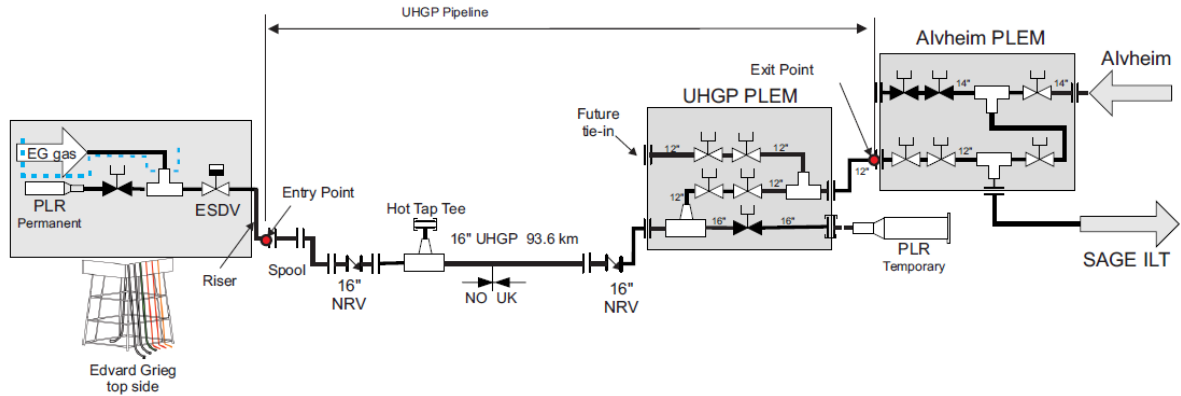

Figure 3 Exit Point 1